

iSmartGate SE

Intelligent Gateway

User Manual

Version: V1.1

May 7, 2026



This manual may not be reproduced in whole or in part by any means without the express written permission from CET Electric Technology (CET).

The information contained in this Manual is believed to be accurate at the time of publication; however, CET assumes no responsibility for any errors which may appear here and reserves the right to make changes without notice. Please consult CET or your local representative for latest product specifications.

Limited warranty

- CET Electric Technology (CET) offers the customer a minimum of 12-month functional warranty on the device for faulty parts or workmanship from the date of dispatch from the distributor. This warranty is on a return to factory for repair basis.
- CET does not accept liability for any damage caused by device malfunctions. CET accepts no responsibility for the suitability of the device to the application for which it was purchased.
- Failure to install, set up or operate the device according to the instructions herein will void the warranty.
- Only CET's duly authorized representative may open your device. The unit should only be opened in a fully anti-static environment. Failure to do so may damage the electronic components and will void the warranty.

Table of Contents

Chapter 1 Introduction	5
1.1 Overview.....	5
1.2 Features	5
1.3 Getting more information.....	6
Chapter 2 Installation	7
2.1 Appearance.....	7
2.2 Unit Mounting	7
2.3 RS-485 Wiring	7
2.4 Ethernet Port (10BASE-T/100BASE-TX).....	8
2.5 Antennas Mounting (Optional).....	8
2.6 Insert SIM Card (Optional).....	9
2.7 Power Supply Wiring	9
Chapter 3 Front Panel	10
3.1 Front Panel LED Indicators	10
3.2 Reset Button	10
Chapter 4 Web Interface.....	11
4.1 Setting PC's IP Address	11
4.2 Web Console Login	12
4.3 Comm. Setup	13
4.4 Modbus Gateway.....	17
4.5 Channel Management	23
4.6 Data Cache Management	28
4.7 System Maintenance	41
Chapter 5 Applications.....	48
5.1 Transparent Gateway.....	48
5.1.1 TCP Server Mode	49
5.1.2 TCP Client Mode	49
5.1.3 Multiple Masters	49
5.2 Modbus Gateway.....	50
5.3 Data Cache.....	51
5.4 Data Collection and Management	51
Chapter 6 Modbus Register Map	53
6.1 Analog Input Register	53
6.2 Digital Input Register	53
6.3 Energy Register	53
6.4 Remote Control	53
6.5 AO Register	54
6.6 Time	54
6.7 Data Recorder Log	54
6.7.1 AI Log Buffer	54
6.7.2 PI Log Buffer	54
6.8 Device Configuration	55
6.9 Device Information	55
6.10 Custom Data Registers.....	55
6.10.1 Analog Input Registers.....	55
6.10.2 Digital Input Register	55
6.10.3 Energy Register	56
Appendix A - Technical Specifications	57
Appendix B - Standards Compliance	58
Appendix C - Ordering Guide	59

Chapter 1 Introduction

This chapter provides an overview of the iSmartGate SE and summarizes many of its key features.

1.1 Overview

The iSmartGate SE is an Intelligent Gateway that provides one 10BASE-T/100BASE-TX Ethernet port, two RS-485 ports, one optional built-in 4G modem as well as one optional wireless LoRa port with configurable ISM Bands. Featuring DIN-Rail mounting and compact construction, it is an ideal equipment that serves as a gateway to connect RS-485 and/or LoRa enabled devices to an IP-based Ethernet LAN over an Ethernet network or 4G network for any SCADA or Automation applications. With extensive protocols such as Modbus RTU, Modbus TCP, IEC 60870-5-104 (IEC 104), AnyPolling and optional BACnet/IP, etc., the iSmartGate SE facilitates access to various end devices, and data storage and upload for efficient and reliable data management. Further, the iSmartGate SE has been specifically designed with industrial automation in mind and therefore provides un-surpassed performance and reliability under the harshest industrial or commercial environments.

1.2 Features

Basic Features

- 1x10BASE-T/100BASE-TX(RJ45) with MDI/MDIX auto-detect and 2xRS-485 port are designed to withstand the harshest industrial environments
- One optional built-in 4G LTE CAT1 modem
- One optional LoRa port with configurable ISM Bands for EU863-870, RU864-870, IN865-867, US902-928, AU915-928, AS920-923 and AS923-925
- Built-in Web Server for access to Data, Configuration and Maintenance
- Automatic IP assignment using DHCP and DNS domain name resolution
- Transparent Gateway & Modbus TCP to RTU Gateway between Ethernet port and RS-485/LoRa
 - TCP Server and TCP Client modes
 - Maximum 32 downstream LoRa devices per iSmartGate SE
 - 32 Slave IEDs per RS-485 port
 - Maximum 4 Masters per RS-485/LoRa port
- One-key Reset to Factory Default
- Extended operating temperature

Data Concentration and Management

- Up to 2 Data Caches
- Data collection via Ethernet, RS-485 or LoRa
 - Maximum 128 downstream devices per iSmartGate SE
 - Modbus RTU, Modbus TCP, IEC 104 and Anypolling
- Support Data Recording of AI parameters and Energy parameters per Data Cache
 - Configurable interval from 1min to 60min
 - 15 days @ 1min, 900 days @ 60min
- Data push to external via Ethernet or 4G
 - 4096xAI, 4096xDI, 2048xEnergy, 1024xAO, 1024xDO, 2048xSOE
 - Extensive protocols support: Modbus TCP, IEC 104, MQTT + JSON, HTTP + JSON, AliCloud, Amazon AWS and optional BACnet/IP, etc.
 - Resumable Transfer for historical data
- Support creating virtual devices, as well as performing calculations on virtual data
 - Maximum 32 virtual devices
 - 1024xAI, 1024xDI, 512xVirtual Energy, 64xCustom SOE
- Simple configuration and commissioning via PMC-EasyCom

Time Synchronization

- Battery-backed Real-time Clock @ 6ppm ($\leq 0.5s/day$)
- Time Sync. via Communications such as SNTP, Modbus

1.3 Getting more information

Additional information is available from CET via the following sources:

- Visit www.cet-global.com
- Contact your local representative
- Contact CET directly via email at support@cet-global.com

Chapter 2 Installation

2.1 Appearance

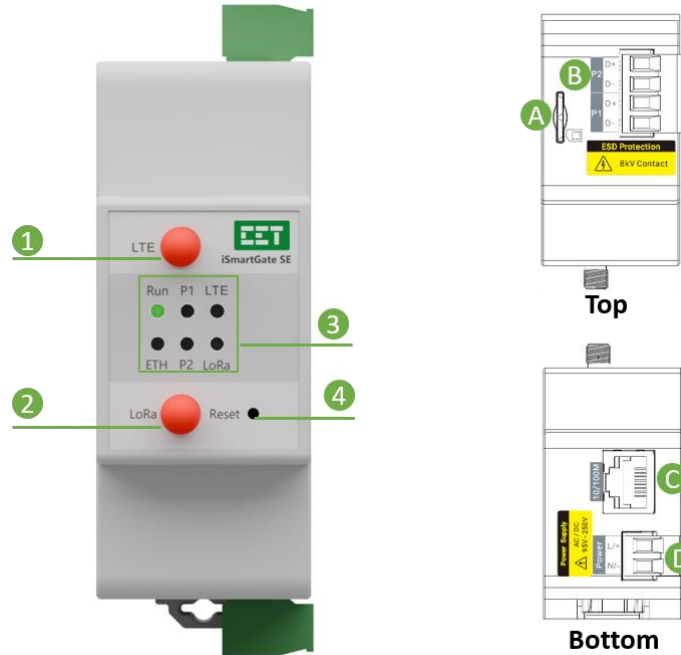

Figure 2-1 Appearance

	Description		Description
1	LTE: 4G Antenna Interface	A	SIM Card Slot
2	LoRa: LoRa Antenna Interface	B	RS-485 Ports (P1, P2)
3	LED Indicators	C	Ethernet Port
4	Reset Key	D	Power Supply Terminal

Table 2-1 Terminal Dimensions

2.2 Unit Mounting

The iSmartGate SE should be installed in a dry environment with no dust and kept away from heat, radiation and electrical noise sources. Installation steps:

- Before installation, make sure that the DIN Rail is already in place.
- Move the installation clip at the back of the iSmartGate SE downward to the “unlock” position.
- Align the top of the mounting channel at the back of the iSmartGate SE at an angle against the top of the DIN Rail as shown in Figure 2-2 right.
- Rotate the bottom of the iSmartGate SE towards the back while applying a slight pressure to make sure that the device is completely and securely fixed on to the DIN Rail.
- Push the installation clip upward to the “lock” position to secure the iSmartGate SE on to the DIN Rail.

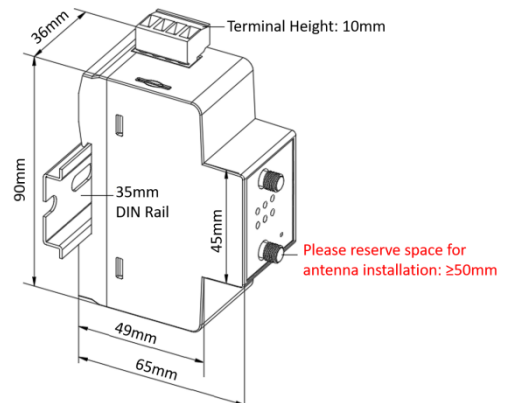

Figure 2-2 DIN-Rail Mounting

2.3 RS-485 Wiring

The iSmartGate SE provides two RS-485 ports (P1 and P2). Up to 32 devices can be connected on each RS-485 bus. The overall length of the RS-485 cable connecting all devices should not exceed 1200m.

The following figure illustrates the RS-485 communications connections on the iSmartGate SE:

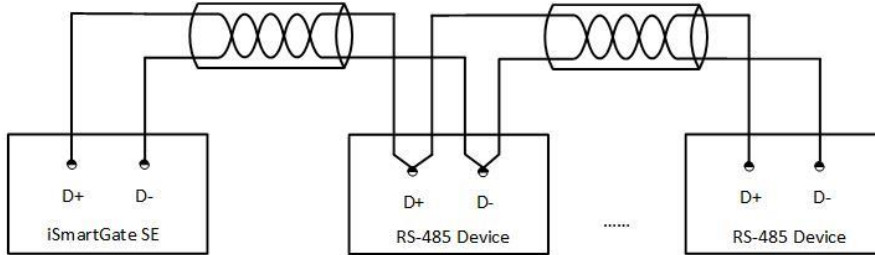

Figure 2-3 RS-485 Communications Connections

2.4 Ethernet Port (10BASE-T/100BASE-TX)

The iSmartGate SE comes standard with an Ethernet Port using the MDI/MIDX Auto-detect RJ45 connector, which means users can connect with a straight-through cable or a cross-over cable. The table below lists the meaning for each pin.

RJ45 Connector	Pin	Meaning
	1	Transmit Data+
	2	Transmit Data-
	3	Receive Data+
	4,5,7,8	NC
	6	Receive Data-

Table 2-2 RJ45 Connector Pin Description for 10BASE-T/100BASE-TX Applications

The figure below shows connections for the straight-through cable and the cross-over cable:

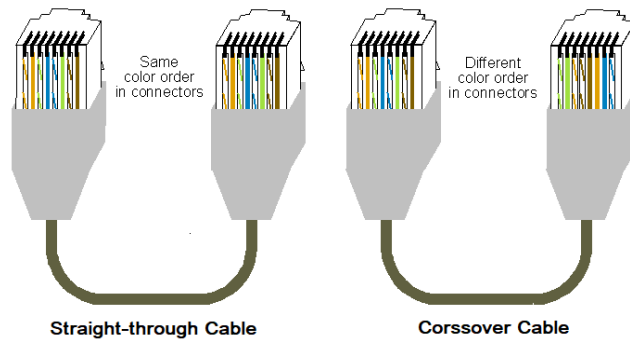

Figure 2-4 Straight-through Cable and Cross-over Cable

2.5 Antennas Mounting (Optional)

Before mounting the LoRa and/or 4G antennas, please check and confirm the two types of them:

- The suction cup on the bottom of the LoRa antenna is marked with 860-935MHz.
- The suction cup on the bottom of the 4G antenna will be marked with the letters '4G'.

For the best communication performance, the antenna should be mounted outside of a metal enclosure and preferably positioned vertically. The base of the antenna is equipped with a magnetic coupler for easy mounting on metal surface.

1. Removed the red SMA dust cap.
2. Carefully rotate the movable part of the metal SMA connector by hand until it can no longer be turned. Do not grasp the black rubber sleeve and forcefully twist the antenna.
3. Screw the LoRa/4G antenna into the LoRa/4G Antenna Interface.



Figure 2-6 Antennas Mounting

2.6 Insert SIM Card (Optional)

Insert the SIM Card to the device's SIM Card Slot at a 45 - degree angle along the flat edge, and then press it firmly into place. To remove the SIM Card, press it again.

Please note that a Micro SIM card should be used.

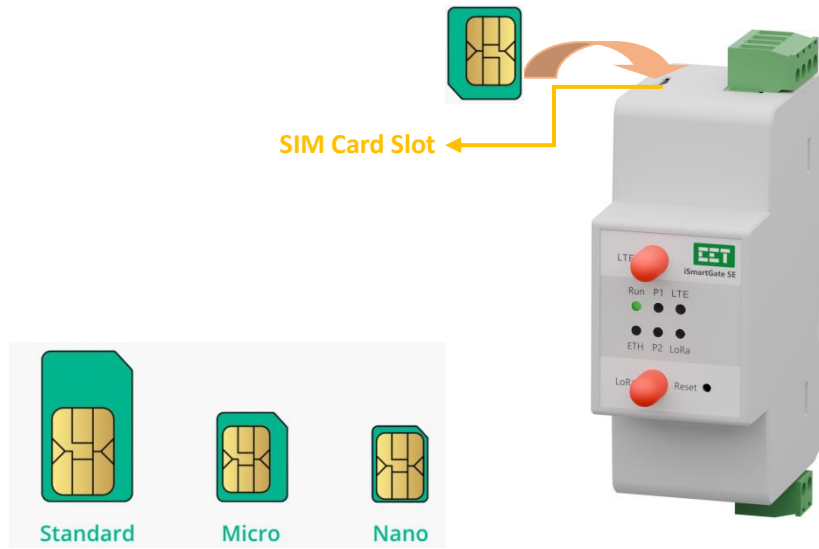

Figure 2-8 Install SIM Card

2.7 Power Supply Wiring

For AC supply, connect the live wire to the L/+ terminal and the neutral wire to the N/- terminal.

For DC supply, connect the positive wire to the L/+ terminal and the negative wire to the N/- terminal.

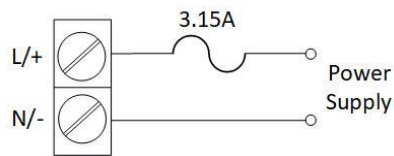
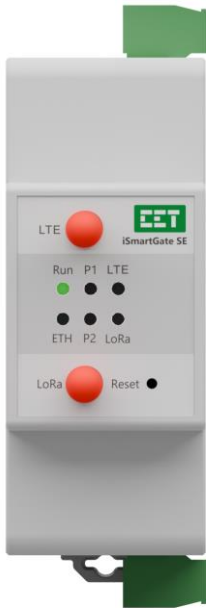

Figure 2-8 Power Supply Connections

Chapter 3 Front Panel

3.1 Front Panel LED Indicators

The table below describes the LED indicators on the iSmartGate SE's Front Panel:



LED Indicator	Color	Status	Function
Run	Green	On	Device is running abnormally.
		Off	Power is off or device is running abnormally.
		Blinking	Power is on and device is running normally.
P1/P2	Green	Blinking	P1/P2 is transmitting data.
LTE	Yellow	On	4G is searching for a network.
		Off	SIM Card is not inserted.
		Blinking Quickly	4G signal is weak.
		Blinking Slowly	4G is transmitting data.
ETH	Yellow	On	The Ethernet Port is connected.
		Off	The Ethernet Port is disconnected.
		Blinking	Receiving or transmitting data via the Ethernet port.
LoRa	Yellow	Blinking	Receiving or transmitting data via LoRa.
		Off	LoRa Communications is disabled or abnormal.

Table 3-1 LED Indicators

3.2 Reset Button

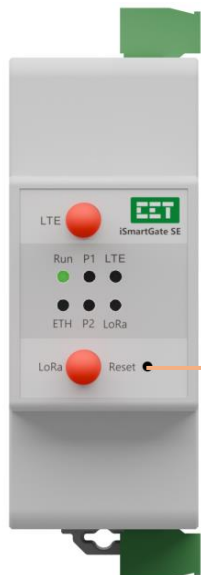

Reset button

The iSmartGate SE provides a **Reset** button at the lower right-hand corner of the front panel to reboot or load factory default settings.

- **Reboot the iSmartGate SE**

Press and hold the **Reset** button for less than 5 seconds, the iSmartGate SE will then reboot. The reboot process would be completed in approximately 30 seconds and the **Run** indicator blinks again.



- **Reset the iSmartGate SE to Factory Default**

Press and hold the **Reset** button for more than 5s and the **Run** indicator blinks at 0.5s for 3 times. This will reset the iSmartGate SE to its default factory configuration.

Chapter 4 Web Interface

The default IP Address of the iSmartGate SE's Ethernet Port is 192.168.0.127. Please make sure to configure the IP Address and Subnet Mask for the iSmartGate SE and the PC, so that they are in the same subnet.

4.1 Setting PC's IP Address

- 1) To determine the PC's IP Address, click the **Start** icon , then the **Settings** button  on Windows 10 (for other MS Windows systems, please refer to this [link](#) for more instructions).

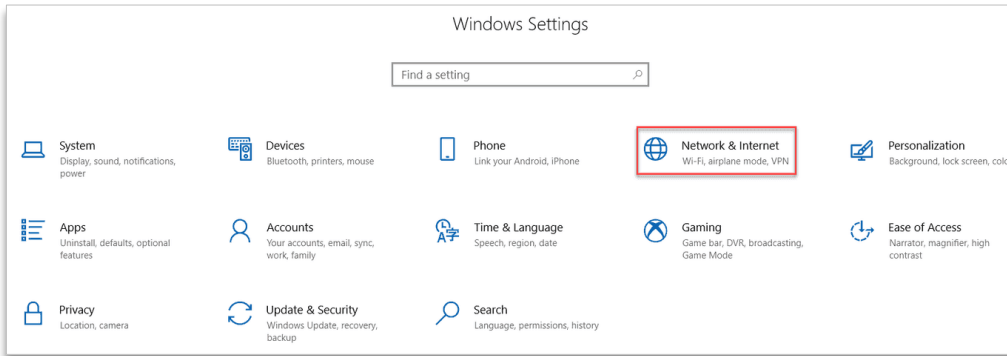

Figure 4-1 Settings-> Network & Internet

- 2) Click  **Network & Internet** and select the **Change adapter options**, and then find the appropriate Ethernet connection.

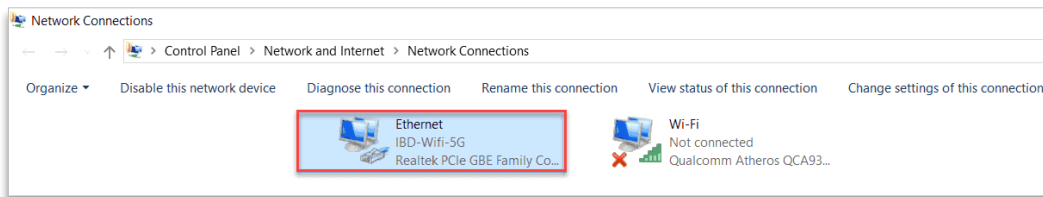

Figure 4-2 Network Connections

- 3) Right-click on the Ethernet connection and select **Properties**. Then double-click on **Internet Protocol Version 4 (TCP/IPv4)** to show its IP configuration.

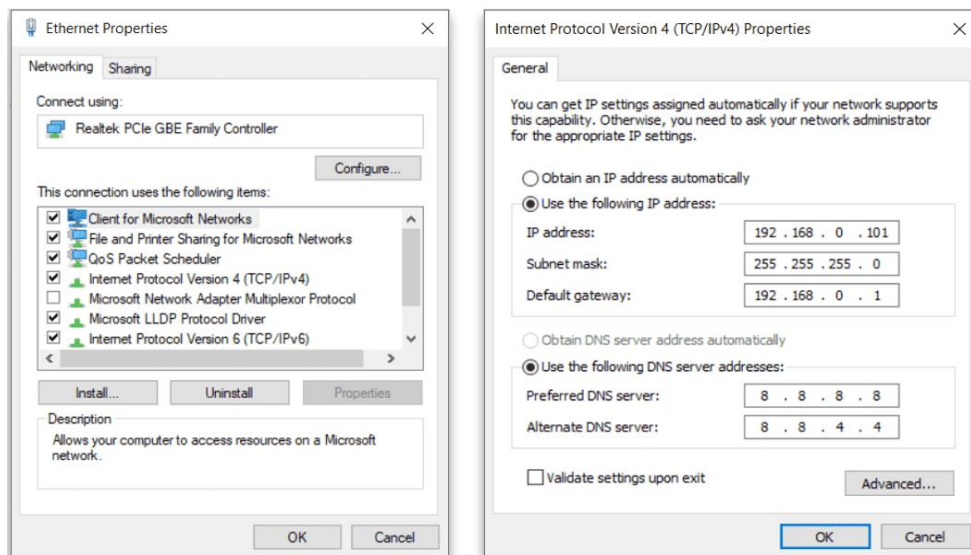

Figure 4-3 Ethernet Properties

4.2 Web Console Login

The iSmartGate SE's Web Interface is compatible with various web browsers.

Browser	Browser Version
Internet Explorer	IE10 and above
Firefox	24.0 and above
Google Chrome	35.0 and above

Table 4-1 Supported Web Browser

- 1) Enter the IP Address (e.g. 192.168.0.127) of the iSmartGate SE in the Address input box of the Internet Explorer and then press **Enter**.
- 2) The iSmartGate SE's Web Console login page appears. Enter the User name and Password and then click **Login**. The default web user name and password are "user" and "123456", respectively.

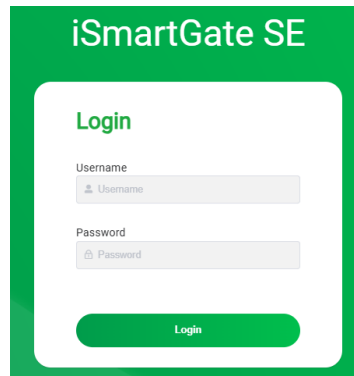

Figure 4-4 The Login Page of Web Console

- 3) The **Comm. Setup** page (first page displayed upon user login) appears. There are five items at the left pane - **Comm. Setup**, **Modbus Gateway**, **Channel Management**, **Data Cache Management** and **System Maintenance**.

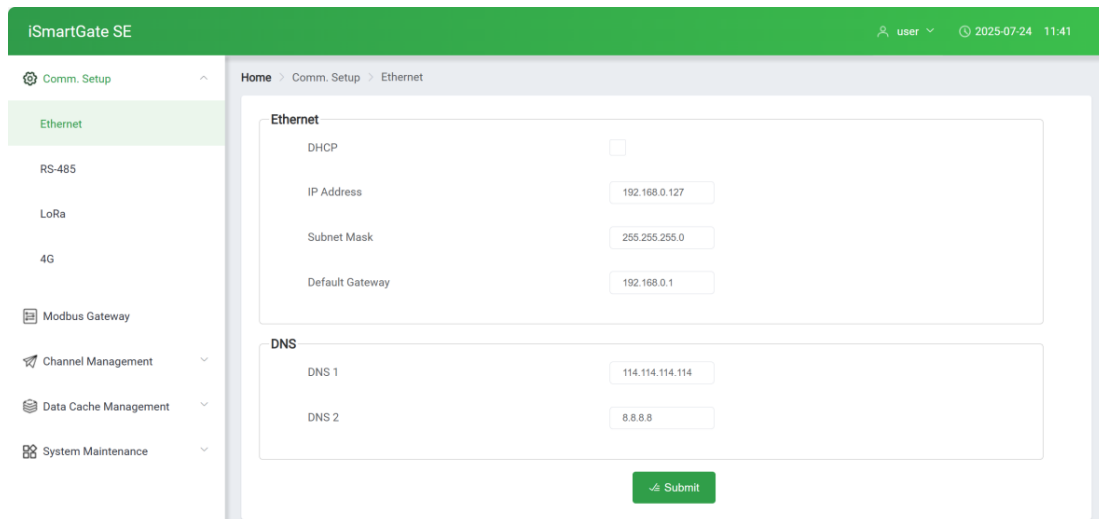

Figure 4-5 The First Page of Web Console

- 4) The Web Console's login password can be changed by clicking on the down arrow at the upper right-hand corner of the page and then selecting **Change Password** as shown below. Users also can change password via **System Maintenance > Password Reset**, please see **Section 4.7.1**.

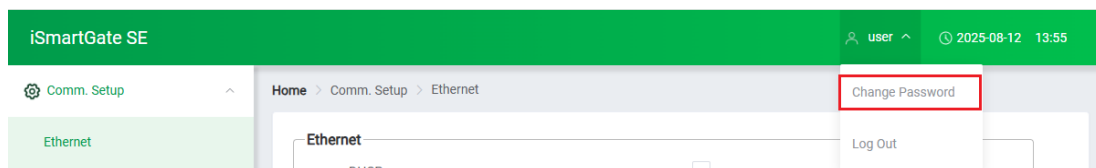

Figure 4-6 Change Login Password

4.3 Comm. Setup

Click **Comm. Setup** on the left-hand pane and its sub-menus appears which includes **Ethernet**, **RS-485**, **LoRa** (LoRa option only) and **4G** (4G option only). The following sections provide a quick overview for these sub-menus.

4.3.1 Ethernet

Click **Ethernet** on the left-hand pane and the following screen appears on the right-hand pane. The **Ethernet** port's settings can be configured here based on the actual situation.

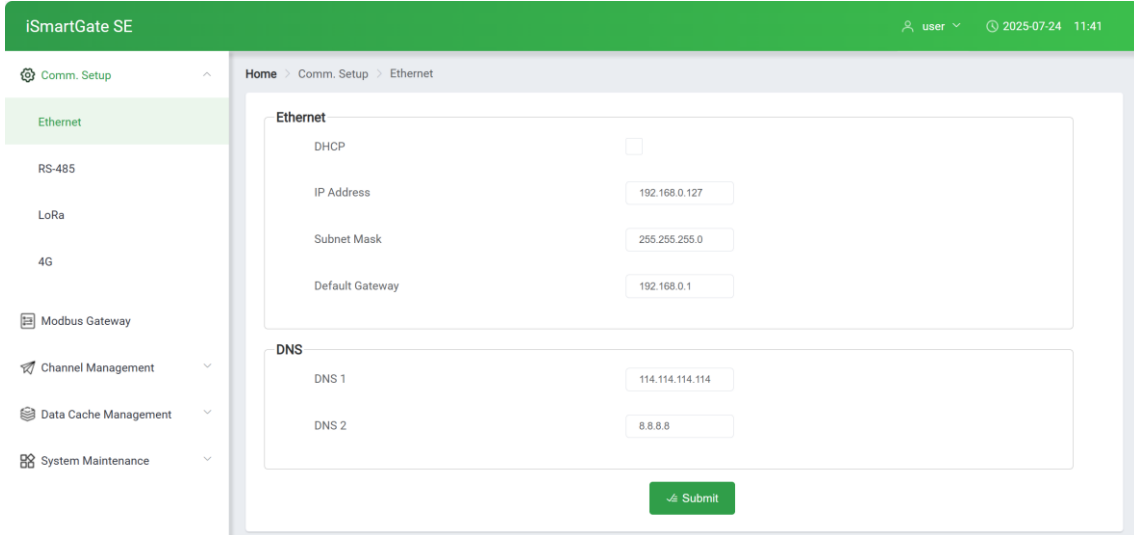

Figure 4-7 Ethernet Settings

Parameter	Range/Option, Default*
Ethernet (The IP Address and Default Gateway should be in the same subnet)	
DHCP	Assign IP automatically using DHCP by checking the DHCP box. It is recommended to set this parameter after all configurations have been completed and saved, and make sure the on-site DHCP server is powered on. If this parameter is accidentally changed and the device cannot be connected, restoring the device to its factory defaults will reset the IP address to the default (192.168.0.127).
IP Address	192.168.0.127*
Subnet Mask	255.255.255.0*
Default Gateway	The IP address of the iSmartGate SE that provides network access outside the server's LAN (Local Area Network). 192.168.0.1*
DNS (DNS allows users to access websites using easy-to-remember names instead of numerical IP addresses. The IP address of the DNS server should be configured to enable access the host via their domain names. DNS2 is included as a backup for use when DNS1 is unavailable.)	
DNS 1	Primary DNS server 1 address. 114.114.114.114*
DNS 2	Secondary DNS server 2 address. 8.8.8.8*

Table 4-2 Ethernet Setup Parameters

Click **Submit** once you have finished setting up for each category and then reboot the device via clicking **Reboot** under **System Maintenance** to apply the changes.

4.3.2 RS-485

The iSmartGate SE is equipped with two independent RS-485 ports.

Click **RS-485** on the left-hand pane and the following screen appears on the right-hand pane, the **P1 (RS-485)** and **P2 (RS-485)** can be configured independently here based on the actual situation. After configuration, click **Submit** to save your changes.

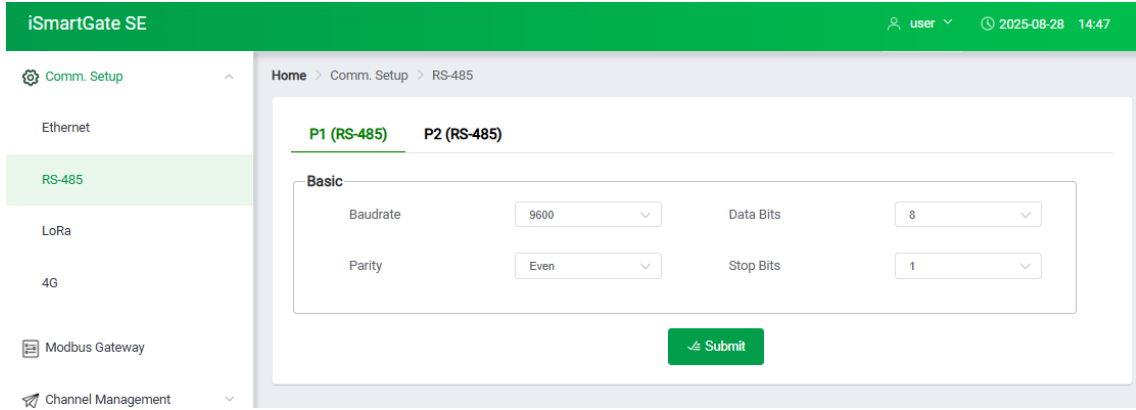

Figure 4-8 RS-485 Settings

The following table lists the setup parameters for P1 and P2. Some setup parameters are basic and self-explanatory. Please note that the following parameters' settings should be consistent with the downstream IEDs' configuration.

Parameters	Range/Option, Default*
Baudrate	300, 600, 1200, 2400, 4800, 9600*, 19200, 38400.
Data Bits	5, 6, 7, 8*
Parity	None, Odd, Even*
Stop Bits	1*, 2

Table 4-3 RS-485 Setup Parameters

4.3.3 LoRa

The iSmartGate SE comes optionally with one LoRa port. Click **LoRa** on the left-hand pane and the following screen appears on the right-hand pane, and the LoRa port can be configured here based on the actual situation.

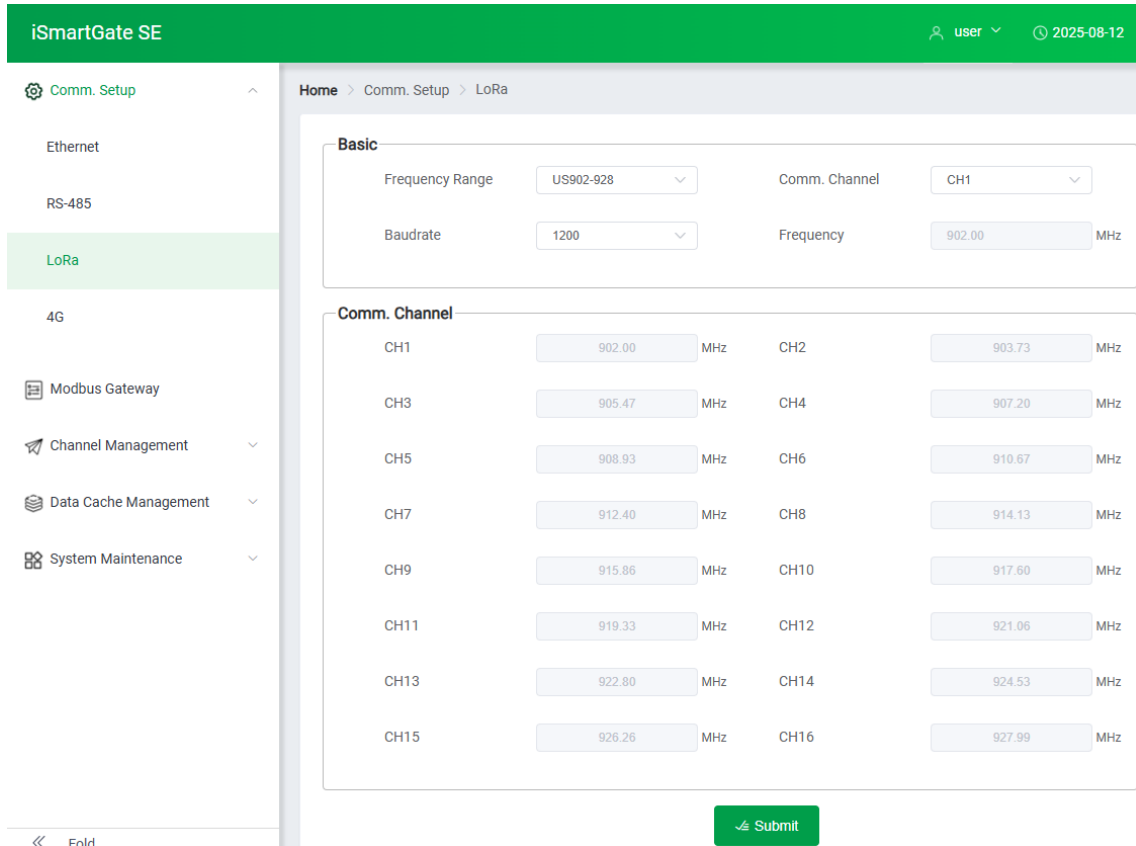

Figure 4-9 LoRa Settings

Parameter	Range/Option, Default*
Basic	
Frequency Range	EU863-870, RU864-870, IN865-867, US902-928, AU915-928, AS920-923, AS923-925*, Custom and Advanced
Comm. Channel	See Table 4-5 , CH1*
Baudrate	1200*, 2400, 3800, 7500, 15000
Frequency	923.00 MHz*
The parameters below are only displayed when the Frequency Range is set to Advanced . These parameters are for connecting a 3 rd party device.	
Spreading Factor	6, 7, 8, 9*, 10, 11
Bandwidth	125kHz*, 250kHz, 500kHz
Code Rate	4/5, 4/6*, 4/7, 4/8
Low Speed Optimization	Enable this parameter by checking the box.

Table 4-4 LoRa Settings

Region Channel	EU 863-870	RU 864-870	IN 865-867	US 902-928	AU 915-928	AS 920-923	AS 923-925	Custom (Default)
CH1	863.00	864.00	865.00	902.00	915.00	920.00	923.00	915.00
CH2	863.47	864.41	865.33	903.73	915.87	920.33	923.29	915.33
CH3	863.93	864.81	865.66	905.47	916.73	920.66	923.57	915.66
CH4	864.40	865.21	865.99	907.20	917.60	920.99	923.86	915.99
CH5	864.87	865.61	866.32	908.93	918.47	921.32	924.14	916.32
CH6	865.34	866.01	866.65	910.67	919.34	921.65	924.43	916.65
CH7	865.80	866.40	866.98	912.40	920.20	921.98	924.71	916.98
CH8	866.27	866.80	867.31	914.13	921.07	922.31	924.99	917.31
CH9	866.74	867.20	867.64	915.86	921.94	922.64	920.10	917.64
CH10	867.20	867.60	867.97	917.60	922.80	922.97	920.46	917.97
CH11	867.67	867.99	868.30	919.33	923.67	923.30	920.82	918.30
CH12	868.14	868.39	868.63	921.06	924.54	923.63	921.18	918.63
CH13	868.60	868.79	868.96	922.80	925.40	923.96	921.54	918.96
CH14	869.07	869.19	869.29	924.53	926.27	924.29	921.91	919.29
CH15	869.54	869.59	869.62	926.26	927.14	924.62	922.27	919.62
CH16	869.99	869.99	869.95	927.99	927.99	924.95	922.63	919.95

Table 4-5 16 Channel Assignments

If **Frequency Range** is set as **Custom**, the **Comm. Channels** can be edited. The valid range of Frequency is 860.00-935.00MHz. If users enter a value less than 860.00 or larger than 935.00, the input value will be reset to 860.00 or 935.00 automatically after clicking anywhere outside the text box. The channel frequency assignment must be unique.

Basic

Frequency Range: Comm. Channel:

Baudrate: Frequency: MHz

Comm. Channel

CH1: <input type="text" value="860.00"/> MHz	CH2: <input type="text" value="860.00"/> MHz
CH3: <input type="text" value="935.00"/> MHz	CH4: <input type="text" value="915.99"/> MHz
CH5: <input type="text" value="935.00"/> MHz	CH6: <input type="text" value="916.65"/> MHz
CH7: <input type="text" value="916.98"/> MHz	CH8: <input type="text" value="917.31"/> MHz
CH9: <input type="text" value="917.64"/> MHz	CH10: <input type="text" value="917.97"/> MHz
CH11: <input type="text" value="918.30"/> MHz	CH12: <input type="text" value="918.63"/> MHz
CH13: <input type="text" value="918.96"/> MHz	CH14: <input type="text" value="919.29"/> MHz
CH15: <input type="text" value="919.62"/> MHz	CH16: <input type="text" value="919.95"/> MHz

Figure 4-10 LoRa Custom Channel Settings

4.3.4 4G

The iSmartGate SE is optionally equipped with one 4G port for Internet access. A micro-SIM card with the frequency bands supported by the iSmartGate SE is required to be inserted to get connected to the mobile network. By default, it should be plug-and-play.

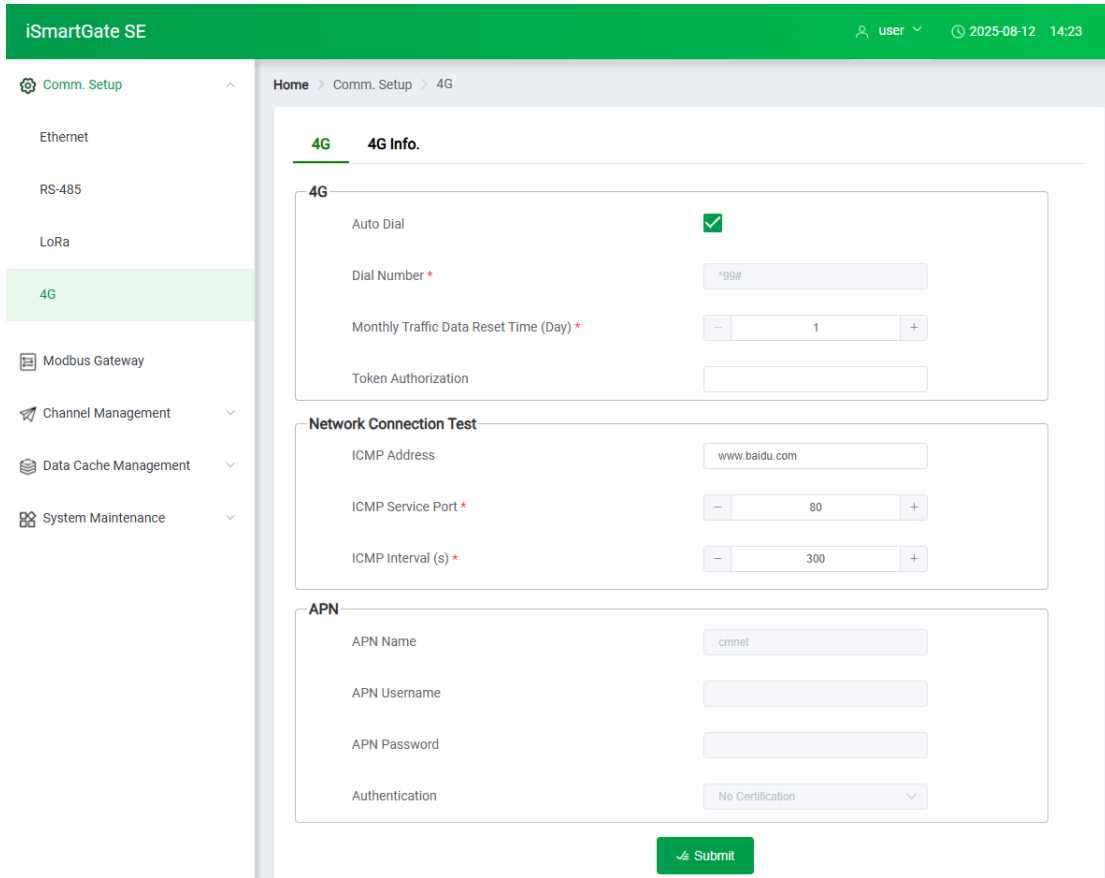

Figure 4-11 4G Settings

The following table illustrates the setup range and default values of the 4G parameters.

Parameter	Range/Option, Default*
4G (The iSmartGate SE supports both Auto Dial and Manual Dial functions, with Auto Dial set as the default.)	
Auto Dial	When using a public network SIM card, Auto Dial can be enabled for automatic dialing. Simply insert the SIM card, and the device will automatically connect to the internet upon powering on. Note that when Auto Dial is enabled, the dial number cannot be modified.
Dial Number	Access Number, provided by carrier. *99# (default), less than 20 ASCII characters
Monthly Traffic Data Reset Time (Day)	Specifies the day of the month when your carrier resets your data usage. 1* to 28
Token Authorization	Token Authentication is a protocol that enables users to verify their identity, in exchange for which they receive a unique access token. This token is provided by the SIM card carrier.
Network Connection Test	
ICMP Address	ICMP (Internet Control Message Protocol) The ICMP address is used to detect whether the Internet connection is normal, or alternatively to verify the IP address or domain name. www.baidu.com *, less than 70 ASCII characters
ICMP Service Port	Specifies the port used for detecting the address. 1 to 65535, 80*
ICMP Interval (s)	Specifies the interval for periodic ping detection. 0 to 60000 (s), 300*
APN (Access Point Name)	
APN Name	Access Point Name. Provided by carrier. Less than 20 ASCII characters, cmnet*

Username	Username for APN login. Provided by carrier. Null*, less than 20 ASCII characters
Password	Password for APN login. Provided by carrier. Null*, less than 20 ASCII characters
Authentication	Some carriers require a specific verification method. Please confirm the required method with your carrier or keep the default setting. <ul style="list-style-type: none"> • No Certification* (= No verification is required) • PAP (= Password Authentication Protocol) • CHAP (= Challenge Handshake Authentication Protocol) • PAPCHAP (= A combination of PAP and CHAP)

Table 4-6 4G Setup Parameters

The following table illustrates the Frequency Bands supported by iSmartGate SE.

Network Type	Frequency Band		
	EU	SA	NA
4G LTE	B1/B3/B5/B7/B8/B20	B1/B2/B3/B4/B5/B7/B8/B28/B66	B1/B2/B3/B4/B5/B7/B8/B12/B13/B14/B18/B19/B20/B25/B26/B28/B34/B38/B39/B40/B41/B66/B71
2G GSM	900/1800 MHz		

Table 4-7 Frequency Bands supported by iSmartGate SE

Click **4G Info.** tab to display dialing result.

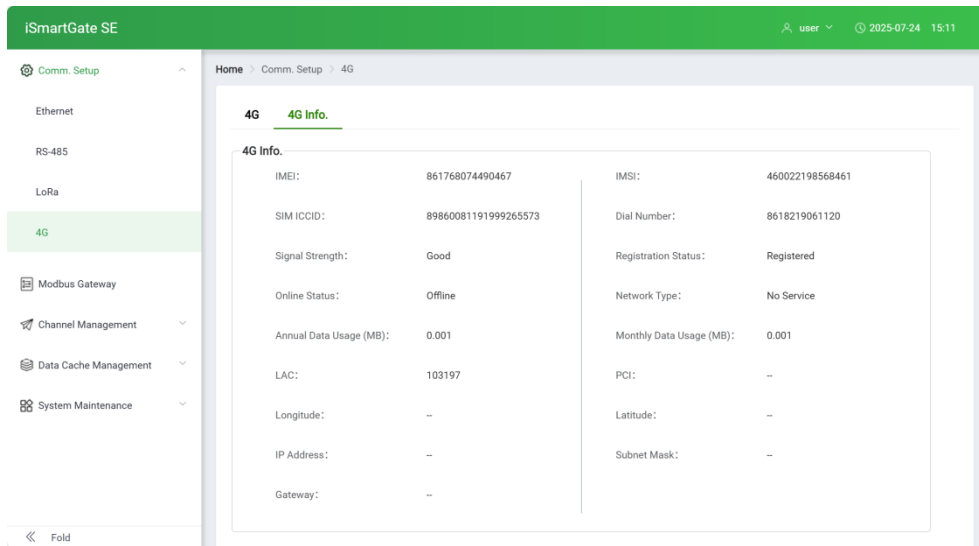

Figure 4-12 4G Info. Screen

4.4 Modbus Gateway

Click **Modbus Gateway** in the left-hand pane to access the screen below where you can configure P1 (RS-485), P2 (RS-485), and optional LoRa, when the iSmartGate SE functions as a Transparent Gateway, Modbus Gateway, or MQTT Gateway.

4.4.1 Transparent Gateway

- Transparent Gateway -> TCP Server

Figure 4-13 Transparent Gateway - TCP Server Settings

- Transparent Gateway -> TCP Client

Figure 4-14 Transparent Gateway - TCP Client Settings

Parameters	Range/Option, Default*
Basic	
Enable	Check this box to enable the P1/P2/LoRa servers as a Modbus Gateway, in which case they cannot be set as acquisition channels. Therefore if enable this parameter, the following message will be promoted: "The acquisition channel is mutually exclusive with the Modbus Gateway. Enabling the Modbus Gateway will automatically exit the current channel's acquisition function."
Packet Interval	The maximum time gap between two consecutive bytes to be identified as the same data packet (frame). 0~60000ms, 20ms*
Idle Timeout	Defines the maximum duration of inactivity after which the connection will be automatically terminated.

	0 (always online) ~ 60000s, 300*
Packet Length	Defines the maximum allowed bytes of a packet transmitted. Payload exceeding this length will be split into multiple packets. 1 ~ 1024* bytes
Multi Master	Select Enable and click Configure to setup Polling Delay and Packet Timeout . Polling Delay: Specifies the mandatory delay interval the gateway inserts after processing a request/response cycle for one device before processing the next request for another device on the same RS-485 bus. This delay ensures stable bus turnover and prevents data collisions on the shred RS-485 bus when the gateway is rapidly switching between handling requests from different network clients aimed at different serial devices. 0 ~ 60000ms, 30ms* Packet Timeout: Defines the maximum time the gateway will wait to receive the first byte of a response from a Modbus RTU device after it has forwarded a request from a network client. This timeout determines if a connected Modbus RTU device is non-responsive. If no data is received from the serial device within this period, the gateway concludes the transaction and becomes available after the Polling Delay for the next transaction. 0 ~ 60000ms, 1000ms*
Advanced	
Protocol	Transparent Gateway
Mode	TCP Server, TCP Client
TCP Server	
Local IP Port	1024 ~ 65535, 30001* (P1), 30002* (P2), 30003*(LoRa) The Local IP Port for the P1 and P2 should be different.
TCP Client	
Registration Packet	Before any normal data exchange, the gateway sends a custom hexadecimal packet to the master immediately after the connection is established. This serves two purposes: 1. Allows the master to verify active communication by receiving this packet from the iSmartGate SE. 2. Enables the master to identify the iSmartGate SE based on its device-specific information. Up to 63 bytes (represented as two-character hexadecimal values, 00~FF) can be configured. Null* (The iSmartGate SE won't send Registration Packet)
Heartbeat Packet	A custom hexadecimal packet is sent by the gateway to the master periodically to maintain an active connection and thus prevent timeout disconnection due to inactivity. Up to 63 bytes of 16 decimal characters (00~FF) can be configured. Null (Do not send a heartbeat packet)
Heartbeat Interval	Specifies the interval for sending heartbeat packets. 0* ~ 60000. 0 means do not send a heartbeat packet.
Reconnect Interval	Defines the delay before the gateway attempts to reconnect to the master following a connection failure. 0 ~ 60000s, 300s
Number of Network Connections (Only display for TCP Client mode)	
Dest. Address 1 to Dest. Address 4	Up to 4 Masters can be configured. Specifies the IP addresses of TCP Masters or IEDs that the iSmartGate SE will connect to.
Dest. Port 1 to Port 4	1 ~ 65535, 502*

Table 4-8 Transparent Gateway Setup Parameters

4.4.2 Modbus Gateway

- Modbus Gateway -> TCP Server

Figure 4-15 Modbus Gateway - TCP Server Settings

- Modbus Gateway -> TCP Client

Figure 4-16 Modbus Gateway - TCP Client Settings

Parameters	Range/Option, Default*
Basic	
Enable	Check this box to enable the P1/P2/LoRa servers as a Modbus Gateway, in which case they cannot be set as acquisition channels. Therefore if enable this parameter, the following message will be promoted: "The acquisition channel is mutually exclusive with the Modbus Gateway. Enabling the Modbus Gateway will automatically exit the current channel's acquisition function."
Packet Interval	The maximum time gap between two consecutive bytes to be identified as the same data packet (frame). 0 ~ 60000ms, 20ms*
Idle Timeout	Defines the maximum duration of inactivity after which the connection will be automatically terminated. 0 (always online) ~ 60000s, 300*
Packet Timeout	Packet Timeout is the timeout setting for IP connections, not for serial or LoRa connections. This means IP connections will be closed if no activity occurs between the application software and the iSmartGate SE after the specified timeout period. This is to prevent potential IP connection failures on the iSmartGate SE if the application software fails to close the IP connections due to unforeseen issues. 0 ~ 60000ms, 1000ms*
Advanced	
Protocol	Modbus Gateway
Mode	TCP Server
TCP Server	
Local IP Port	502 ~ 65535, 502* (P1), 503* (P2), 504*(LoRa) The Local IP Port for the P1 and P2 should be different.
Polling Delay	Set polling interval for multiple downstream Modbus RTU devices located in RS-485 port. 0 ~ 60 000ms, 30ms*
TCP Client	
Registration Packet	Before any normal data exchange, the gateway sends a custom hexadecimal packet to the master immediately after the connection is established. This serves two purposes: <ol style="list-style-type: none"> Allows the master to verify active communication by receiving this packet from the iSmartGate SE. Enables the master to identify the iSmartGate SE based on its device-specific information. Up to 63 bytes (represented as two-character hexadecimal values, 00~FF) can be configured. Null* (The iSmartGate SE won't send Registration Packet)
Heartbeat Packet	A custom hexadecimal packet sent by the gateway to the master periodically to maintain an active connection and prevent timeout disconnection due to inactivity. Up to 63 bytes of 16 decimal characters (00~FF) can be configured. Null (Do not send a heartbeat packet)
Heartbeat Interval	The interval of sending a heartbeat packet. 0* ~ 60000. 0 means do not send a heartbeat packet.
Reconnect Interval	Defines the delay before the gateway attempts to reconnect to the master after a connection failure. 0 ~ 60000s, 300s
Cache (Only display for TCP Server mode)	
Cache	With cache function enabled, gateway stores frequently accessed Modbus register values (Read-only) in local memory, allowing it to respond instantly to TCP client requests with the cached data. Meanwhile, the gateway automatically refreshes the cache by periodically polling the connected devices in the background. Enable, Disable
TTL	TTL (Time-To-Live) Specifies survival time for cache function code, once TTL expires, the cached data is automatically cleared. For example, setting TTL to 5 mins means the iSmartGate SE will remove this function code when it doesn't receive message from the masters after 5 mins. 0 ~ 60000s, 300s*

Cache Code 1 to 6	Each Cache Code maintains independent cache storage. 0x01, 0x02, 0x03, 0x04 and two customized cache codes. 0 means disabled. Only Read function code can be configured.
Modbus Slave ID Map (Only display for TCP Server mode)	
When connecting multiple ModbusTCP masters to a serial port server, the sent message uses the serial device' virtual address which has a certain mapping relationship with the real address to distinguish which master sent the message. The iSmartGate SE will converts the received command into the real address of the serial port device and sends it to the corresponding device. The data return also follows this path to ensure that only the master that sent the command receives the command. Mapping relationship: Unit ID (Local)=Map ID (Remote)+Offset	
Map ID (Remote)	Note: Only Modbus TCP messages with a unit identifier within the virtual address range will be forwarded, otherwise, they will be filtered and discarded.
Offset	-246 ~ 246, 0*
Unit ID (Local)	1 ~ 247
Number of Network Connections (Only display for TCP Client mode)	
Dest. Address 1 to 4	IP/domain name for TCP Servers that the iSmartGate SE wishes to connect with. Up to 4 TCP Servers can be configured
Dest. Port 1 to 4	Service Port of TCP Server. 1 ~ 65535, 502*
Modbus ID Range	Modbus address range. The data from the serial devices that within this address range will be forwarded to the corresponding destination network address. 1 ~ 247

Table 4-9 Modbus Gateway Setup Parameters

4.4.3 MQTT

Basic

Enable Idle Timeout (0~60000) s

Advanced

Protocol Mode

Server Address Server Port (1~65535)

Username Password

Client ID Head Packet

Publish Topic Subscribe Topic

Heartbeat Interval (0~60000) s Enable TLS

Upload TLS Certificate

Figure 4-17 MQTT Gateway

Parameters	Range/Option, Default*
Basic	
Enable	Check this box to enable the P1/P2/LoRa servers as a Modbus Gateway, in which case they cannot be set as acquisition channels. Therefore if enable this parameter, the following message will be promoted: "The acquisition channel is mutually exclusive with the Modbus Gateway. Enabling the Modbus Gateway will automatically exit the current channel's acquisition function."
Idle Timeout	Define the maximum duration of inactivity after which the connection will be automatically terminated. 0 (always online) ~ 60000s, 300*
Advanced	
Protocol	MQTT
Mode	Fixed as MQTT Client.
Server Address	The LAN IP address, fixed public IP address, or dynamic/static domain name address of the

	main station that iSmartGate SE needs to connect to.
Server Port	The port no. of the main station.
Username	Provided by the main station.
Password	Provided by the main station.
Client ID	Each device connecting to the MQTT Broker must have a unique ClientID.
Head Packet	The data packets sent by iSmartGate SE at regular intervals to the server to maintain the connection.
Publish Topic	Where messages are sent.
Subscribe Topic	Where messages are received.
Heartbeat Interval	The interval of sending a heartbeat packet. Heartbeat is a function to notify the reachability to the other router by sending a packet containing its own name and IP address. 0* ~ 60000. 0 means do not send a heartbeat packet.
Enable TLS	Enable Transport Layer Security (TLS) Encryption by checking the box. Disabled TLS Encryption means unencrypted.
Upload TLS Certificate	Select TLS Encryption but do not upload TLS Certificate means one-way authentication. Select TLS Encryption and upload 3 TLS Certificate means two-way authentication. Please note that the certificates should be uploaded one by one.

Table 4-10 MQTT Setup Parameters

4.5 Channel Management

Click **Channel Management** on the left-hand pane and its sub-menus appears which includes **Channel Settings**, **Slave IED Management** and **Driver Management**. The following sections provide a quick overview for these sub-menus.

4.5.1 Channel Settings

The iSmartGate SE provides 4 collection channels:

- Channel 1-2: RS-485 serial ports (P1/P2)
- Channel 3: LoRa
- Channel 4: Ethernet

Note: If the P1/P2/LoRa port is set to Modbus Gateway, it cannot be set as an acquisition channel here anymore.

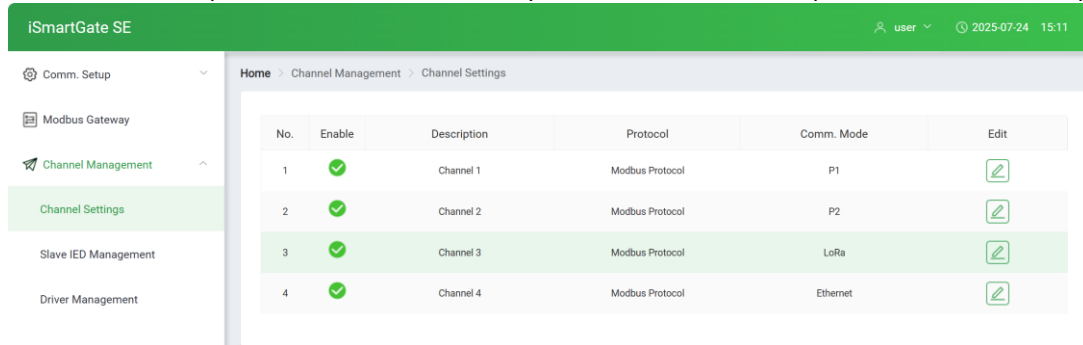

Figure 4-18 Channel Settings Interface

Click the on the right of the channel to edit each channel's parameters.

- For the **Channel 1 to Channel 3 (P1, P2 and LoRa)**:

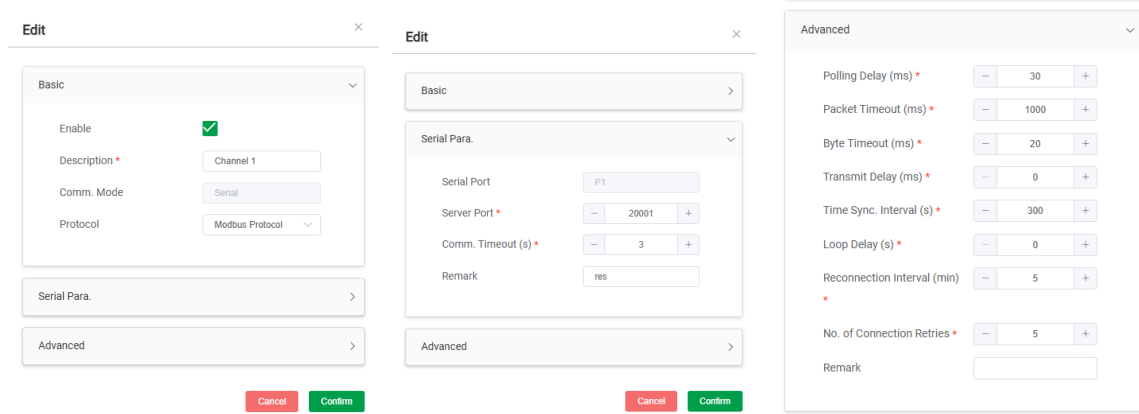

Figure 4-19 Edit Channel Parameters

Parameter	Range/Option, Default*
Basic	
Enable	Enable*, Disable
Description	Channel 1* Channel 1 -> P1 (RS-485), Channel 2 -> P2 (RS-485), Channel 3 -> LoRa
Comm. Mode	P1 and P2: Serial LoRa: LoRa
Protocol	Modbus Protocol *, Anypolling Protocol. Additional protocols can be extended based on customers requirements.
Serial Para./Wireless Para.	
Serial Port	Appears only for the Channel 1 and Channel 2. P1*, P2*
Server Port	Service port when the iSmartGate SE serves as transparent transmission function. 0 ~ 60000. 20001*(P1), 20002*(P2), 20003*(LoRa)
Comm. Timeout (s)	If there is no communication through the port after configured time, the connection will be terminated automatically. 1 ~ 60000s, 3s*
Remark	Reserved extended parameters
Advanced	
(Generally, there is no need to adjust the advanced parameters. However, if the quality of communication fails to meet the required standard, please contact our technical support engineers for assistance.)	
Polling Delay (ms)	When multiple slave IEDs are connected to this channel, this parameter defines the time interval between the acquisition and polling of two IEDs. 0 ~ 60000ms, 30ms*
Packet Timeout (ms)	If the response time exceeds the configured timeout, it is considered that the IEDs have no data reply. 0 ~ 60000ms, 1000ms*
Byte Timeout (ms)	Defines the the gap between two consecutive bytes of data during its transmission. After the configured interval, the message (frame) will be considered as completed. 0 ~ 60000ms, 20ms*
Transmit Delay (ms)	Defines the waiting time before sending an acquisition command. 0 ~ 60000ms, 0ms*
Time Sync. Interval (s)	Defines time synchronization interval when the iSmartGate SE servers as a time server. 0 ~ 60000s, 300s*
Loop Delay (s)	Defines the time interval for acquiring all devices on the same channel. 0 ~ 60000ms, 0s*
Reconnection Interval (min)	Defines the next retry communication time in the event of the iSmartGate SE fails to connect slave IEDs. 0 ~ 60min, 5min*
No. of Connection Retries	Defines the number of communication retries in the event of the iSmartGate SE fails to connect slave IEDs. 0 ~ 60000, 5*
Remark	Reserved extended parameters

Table 4-11 Channel 1-3 Settings

- For the **Channel 4 (Ethernet)**:

Parameter	Range/Option, Default*
Basic	
Enable	Enable*, Disable
Description	Channel 4*
Comm. Mode	Ethernet
Protocol	Modbus Protocol*, IEC104 Protocol Additional protocols can be extended based on customer requirements. When changing the protocol, the system will prompt: "Modifying the protocol will clear all devices under the acquisition channel." To confirm the protocol change, click OK.
Advanced (Generally, there is no need to adjust the advanced parameters. However, if the quality of communication fails to meet the required standard, please contact our technical support engineers for assistance.)	
Polling Delay (ms)	When multiple slave IEDs are connected to this channel, this parameter defines the time interval between the acquisition and polling of two IEDs. 0 ~ 60000ms, 30ms*
Packet Timeout (ms)	If the response time exceeds the configured timeout, it is considered that the IEDs have no data reply. 0 ~ 60000ms, 1000ms*
Byte Timeout (ms)	Defines the the gap between two consecutive bytes of data during its transmission. After the configured interval, the message (frame) will be considered as completed. 0* ~ 60000ms
Transmit Delay (ms)	Defines the waiting time before sending an acquisition command. 0 ~ 60000ms, 0ms*
Time Sync. Interval (s)	Defines time synchronization interval when the iSmartGate SE servers as a time server. 0 ~ 60000s, 300s*
Loop Delay (s)	Defines the time interval for acquiring all devices on the same channel. 0 ~ 60000ms, 0s*
Reconnection Interval (min)	Defines the next retry communication time in the event of the iSmartGate SE fails to connect slave IEDs. 0 ~ 60min, 5min*
No. of Connection Retries	Defines the number of communication retries in the event of the iSmartGate SE fails to connect slave IEDs. 0 ~ 60000, 5*
Remark	Reserved extended parameters

Table 4-12 Channel 4 Settings

4.5.2 Slave IED Management

Click **Slave IED Management** on the left-hand pane and the following screen appears which displays slave IEDs management.

1. Select a specific channel (Channel 1 to Channel 4) by clicking the drop-down menu at the top of the page. Click **Add IED** to add an IED to the selected channel and configure its parameters.

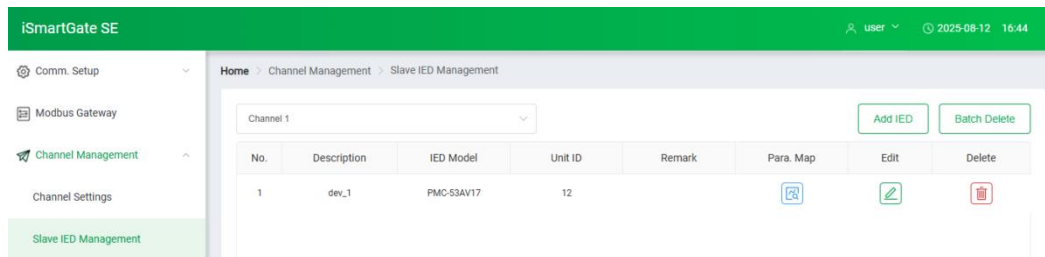

Figure 4-20 Slave IED Management Settings Interface

2. Setup the new IED, then click **Confirm**.
 - IED Model: select from the drop-down box.
 - Description: description of the IED.
 - Unit ID: indicates the communication ID/IP address of the IED when the Serial/Ethernet acquisition channel is selected.

Add IED

IED Model *

Description *

Unit ID *

Remark

Figure 4-21 Add a Slave IED

3. Click **Submit**.

The screenshot shows the iSmartGate SE interface. The top navigation bar is green and contains the text 'iSmartGate SE', a user profile icon labeled 'user', and a clock icon showing '2025-09-11 10:39'. A left sidebar menu includes 'Comm. Setup', 'Modbus Gateway', 'Channel Management', 'Channel Settings', 'Slave IED Management' (highlighted in green), 'Driver Management', 'Data Cache Management', and 'System Maintenance'. The main content area is titled 'Home > Channel Management > Slave IED Management'. It features a dropdown menu for 'Channel 1', 'Add IED' and 'Batch Delete' buttons, and a table with the following data:

No.	Description	IED Model	Unit ID	Remark	Para. Map	Edit	Delete
1	dev_1	PMC-340-A6V10	1				
2	dev_2	PMC-352-DVv09	2				

At the bottom of the table area, there is a green 'Submit' button.

Figure 4-22 Submit for Added Slave IEDs

4. Click  to view the data list of the selected IED.

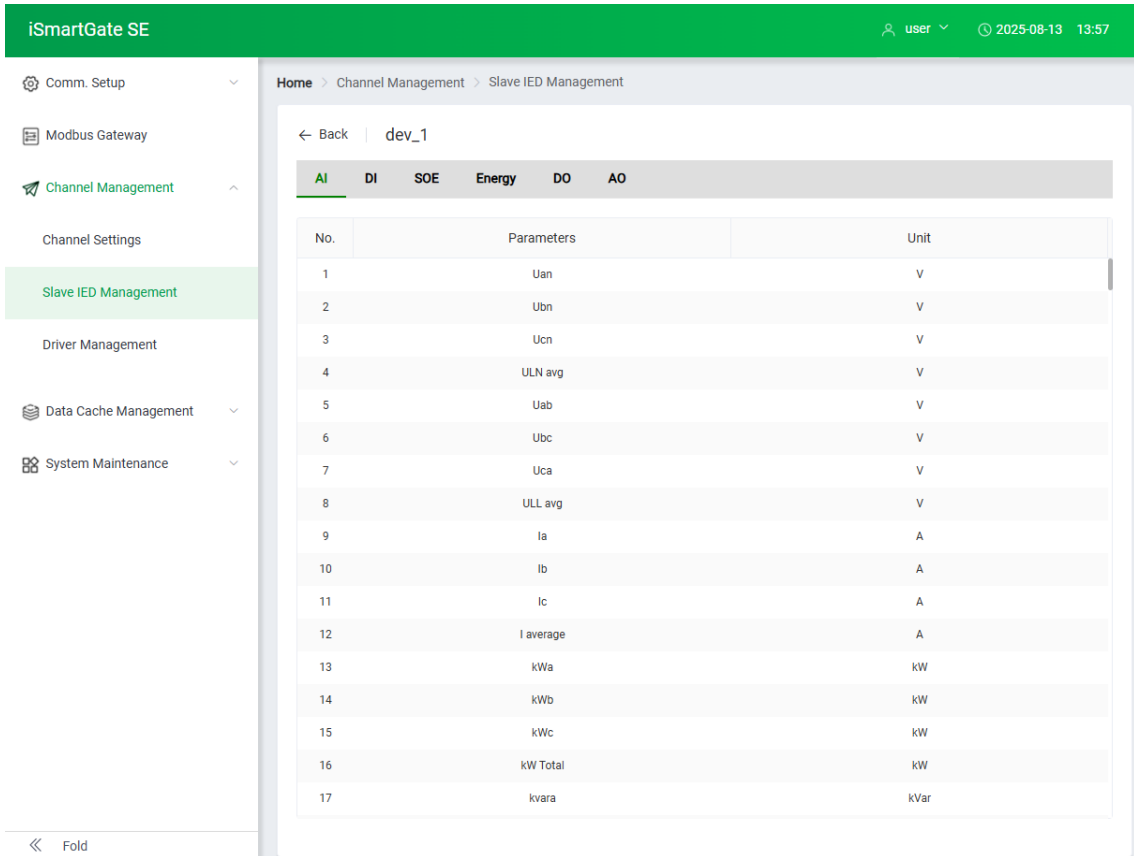



Figure 4-23 Slave IED Management Interface

5. Delete IEDs in batches: click **Batch Delete** and select the IEDs that will be removed, and then click .

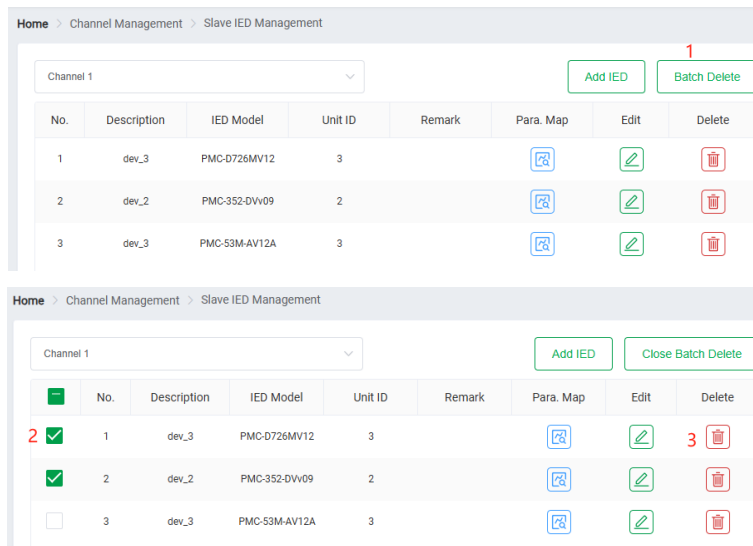



Figure 4-24 Delete IED In Batches

4.5.3 Driver Management

Click **Driver Management** on the left-hand pane and the following screen appears which allows users to view uploaded device drivers and add a new driver file.

Click  to delete a driver. Please note that the  means the corresponding driver is the device's built-in one and cannot be deleted.

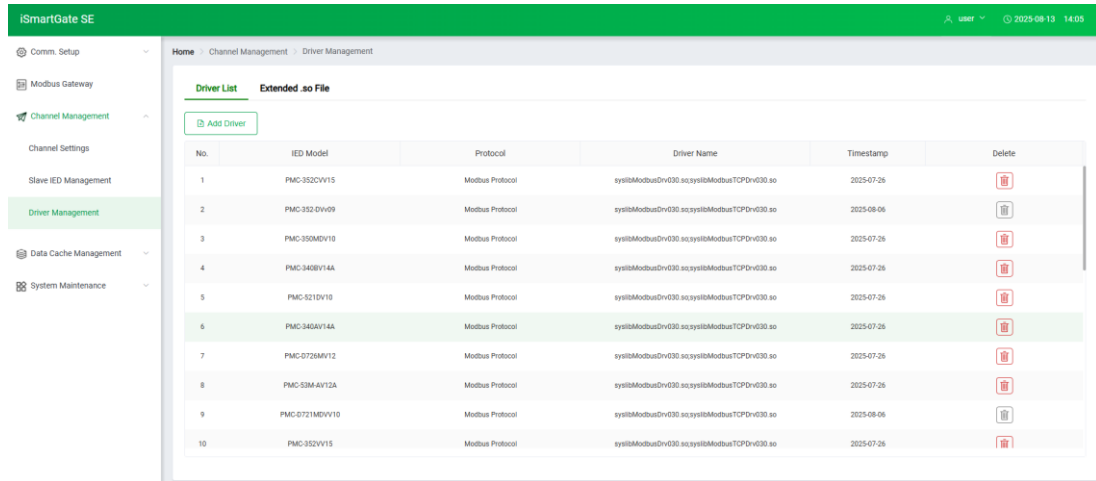

Figure 4-25 Driver Management Screen

To add a new driver file:

1. Click **Add Driver**
2. Click **Click to Upload** to select a driver file in the pop-up dialog.
3. Click **Upload** to upload the selected driver file.

For the 3rd party devices which use non-standard protocols, click **Extended .so File** tab to manage .so files.

4.6 Data Cache Management

Click **Data Cache Management** on the left-hand pane and its sub-menus appear which includes **Cache Management** and **Data Cache**. The following sections provide a quick overview for these sub-menus.

4.6.1 Cache Management

The iSmartGate SE supports up to two independent cache channels. Click **Cache Management** on the left-hand pane and the following screen appears which allows users to setup protocols for the two cache channels.

Click **Protocol** drop-down box to select protocol for the Data Cache x.

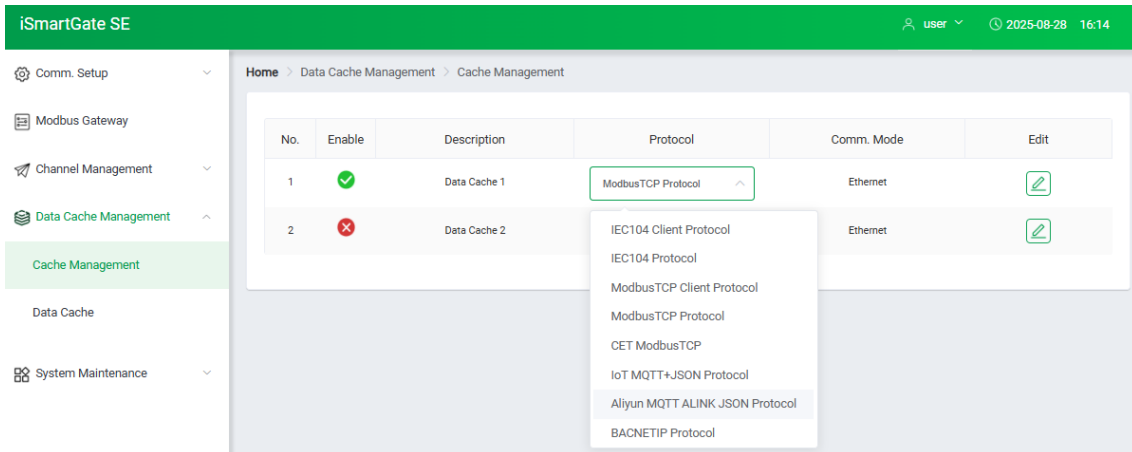



Figure 4- 26 Data Cache Management Interface

Click  to edit other parameters after setting the protocol for the Data Cache.

Note: When the Protocol is configured as **Modbus TCP Protocol**, the number of TCP connections established between the remote master stations and iSmartGate SE cannot exceeds 16.

The **Sections 4.6.1.1** to **4.6.1.7** describe basic and advanced parameters for each of the protocols.

4.6.1.1 Modbus TCP Protocol / Modbus TCP Client Protocol

When set Protocol to Modbus TCP Protocol or Modbus TCP Client Protocol:

The screenshot shows two configuration panels for the Modbus TCP Protocol. The 'Basic' panel includes an 'Enable' checkbox (checked), a 'Description' field (Data Cache 1), a 'Port' spinner (2001), and 16 'Client IP' input fields. The 'Advanced' panel includes various register and function code settings: AI Register Address (0), AI Function Code (0x03), AI Data Type (FLOAT), DI Register Address (20000), DI Function Code (0x03), Energy Register Address (30000), Energy Function Code (0x03), Energy Data Type (INT32), DO Register Address (40000), DO Function Code (0x05), AO Register Address (45000), AO Function Code (0x10), 'Retain Data on Comm Loss' checkbox (unchecked), 'Idle Timeout(min)' spinner (5), 'Data Upload Delay after Restart(s)' spinner (0), and a 'Remark' text area.

Figure 4- 27 Modbus TCP Protocol

Parameter	Range/Option, Default*
Basic	
Port	In scenarios where multiple remote stations access the iSmartGate SE's cache channels, it is imperative that the Master Station IP and Port are configured to differentiate between them. In the event of the same port being required for different cache channels, it is necessary to set different Master Station IPs in order to distinguish between them. A cache channel should be uniquely determined by: Port + Master Station IP. 1 ~ 65535, 2001* for cache channel 1 and 2002* for cache channel 2
Client IP 1~16	The Client IP 1~16 are the IP addresses of the remote stations and only the specified stations are able to retrieve data from iSmartGate SE's cache channels. Setting the Client IP 1~16 as null allows any stations to retrieve data from iSmartGate SE's cache channels.
Advanced	
AI Register Address	0* ~ 65535
AI Function Code	0x01, 0x02, 0x03*, 0x04
AI Data Type	INT8, UINT8, INT16, UINT16, INT32, UINT32, INT64, UINT64, FLOAT*, DOUBLE
DI Register Address	0 ~ 65535, 20000*
DI Function Code	0x01, 0x02, 0x03*, 0x04
Energy Register Address	0 ~ 65535, 30000*
Energy Function Code	0x01, 0x02, 0x03*, 0x04
Energy Data Type	INT8, UINT8, INT16, UINT16, INT32*, UINT32, INT64, UINT64, FLOAT, DOUBLE
DO Register Address	0 ~ 65535, 40000*
DO Function Code	0x05*, 0x06, 0x0F
AO Register Address	0 ~ 65535, 45000*
AO Function Code	0x06, 0x10*
Retain Data on Comm Loss	Checking this box means retaining data upload prior to the communication failure. Unchecking the box will upload invalid values.
Idle Timeout (min)	The connection will be closed if there is no activities between the serial ports in the specified time. 1 ~ 60min, 5*

Data Upload Delay after Restart(s)	After the gateway is reset, it begins to collect and upload IEDs' data to the platform, which will take approximately 2 seconds. During this period, the data sent by the gateway to the platform may be invalid values. Setting this parameter to give the gateway sufficient time to collect valid data from the IEDs and avoid uploading invalid data. 0* ~ 300s
------------------------------------	--

Figure 4- 28 Modbus TCP Protocol

The screenshot shows the configuration interface for the Modbus TCP Client Protocol. It is divided into two main sections: 'Basic' and 'Advanced'.

Basic Section:

- Enable:** Checked (green checkmark).
- Description:** Data Cache 1
- Main Station Address:** (Empty text field)
- Main Station Port:** 10000
- Backup Station Address:** (Empty text field)
- Backup Station Port:** 10000
- Login Packet:** (Empty text field)
- Heartbeat Interval(s):** 0
- Heartbeat Packet:** (Empty text field)
- KeepAlive Interval(s):** 0

Advanced Section:

- AI Register Address:** 0
- AI Function Code:** 0x03
- AI Data Type:** FLOAT
- DI Register Address:** 20000
- DI Function Code:** 0x03
- Energy Register Address:** 30000
- Energy Function Code:** 0x03
- Energy Data Type:** INT32
- DO Register Address:** 40000
- DO Function Code:** 0x05
- AO Register Address:** 45000
- AO Function Code:** 0x10
- Retain Data on Comm Loss:** (Unchecked checkbox)
- Idle Timeout(min):** 5
- Data Upload Delay after Restart(s):** 0
- Remark:** (Empty text field)

Figure 4- 29 Modbus TCP Client Protocol

Parameter	Range/Option, Default*
Basic	
Main Station Address	The connected master station address. Users can set LAN IP address, fixed public IP address, or dynamic/static domain name address.
Main Station Port	The port number of the master station server. 10000*
Backup Station Address	Reserved
Backup Station Port	Reserved
Login Packet	The iSmartGate SE sends data packets when it is actively connecting to the server. These packets can uniquely identify the data packets of a gateway.
Heartbeat Interval (s)	The interval of sending a heartbeat packet. 0* ~ 60000. 0 means do not send a heartbeat packet.
Heartbeat Packet	A custom hexadecimal packet sent by the gateway to the master periodically to maintain an active connection and prevent timeout disconnection due to inactivity. Up to 63 bytes of 16 decimal characters (00~FF) can be configured. Null (Do not send a heartbeat packet).
KeepAlive Interval (s)	A parameter used in network communication (especially in protocols like TCP, MQTT, and HTTP) to maintain persistent connections by periodically sending small packets to prevent timeouts.
Advanced (Please refer to advanced Parameters of Modbus TCP Protocol)	

Table 4-9 Modbus TCP Client Protocol

4.6.1.2 IEC104 Client Protocol / IEC104 Protocol

When set Protocol to IEC104 Protocol or IEC104 Client Protocol:

The screenshot displays two configuration panels for the IEC104 Protocol. The 'Basic' panel includes an 'Enable' checkbox (checked), a 'Description' field (Data Cache 1), a 'Port' field (2404), and 16 'Client IP' fields. The 'Advanced' panel contains various numerical and dropdown settings: Number of Common Address Bytes (2), Number of Transmission Reason Bytes (2), Number of Information Object Bytes (3), AI Start Address (16385), AI Upload Type (ASDU13), DI Start Address (1), DI Upload Type (ASDU1), Energy Start Address (25601), Energy Upload Type (ASDU15), SOE Start Address (1), SOE Upload Type (ASDU30), DO Start Address (24577), AO Start Address (28673), Common Address (1), Upload Virtual SOE (unchecked), Upload AI Change (checked), Energy Upload Interval(s) (0), AI Upload Interval(s) (0), Idle Timeout(min) (5), Data Upload Delay after Restart(s) (0), Remote Time Sync (On), and a Remark field.

Figure 4-30 IEC104 Protocol

Parameter	Range/Option, Default*
Basic	
Port	In scenarios where multiple remote stations access the iSmartGate SE's cache channels, it is imperative that the Master Station IP and Port are configured to differentiate between them. In the event of the same port being required for different cache channels, it is necessary to set different Master Station IPs in order to distinguish between them. A cache channel should be uniquely determined by: Port + Master Station IP. 1 ~ 65535, 2404*
Client IP 1~16	The Client IP 1~16 are the IP addresses of the remote stations and only the specified stations are able to retrieve data from iSmartGate SE's cache channels. Setting the Client IP 1~16 as null allows any stations to retrieve data from iSmartGate SE's cache channels.
Advanced	
Number of Common Address Bytes	1, 2*
Number of Transmission Reason Bytes	1, 2*
Number of Information Object Bytes	2, 3*
AI Start Address	1 ~ 65535, 16385*
AI Upload Type	ASDU9, ASDU11, ASDU13* ASDU9: Transmits data in normalized values ASDU11: Transmits data in scaled values ASDU13: Transmits data in floating-point numbers
DI Start Address	1* ~ 65535
DI Upload Type	ASDU1*, ASDU3 ASDU1: Transmits Single Point Information (SPI) ASDU3: Transmits Double Point Information (DPI)

Energy Start Address	1 ~ 65535, 25601*
Energy Upload Type	ASDU13, ASDU15* ASDU13: Transmits data in floating-point numbers ASDU15: Transmits data in integer format (32-bit signed)
SOE Start Address	1* ~ 65535
SOE Upload Type	ASDU30*, ASDU31 ASDU30: Transmits Single Point SOE (SP-SOE) ASDU31: Transmits Double Point SOE (DP-SOE)
DO Start Address	1 ~ 65535, 24577*
AO Start Address	1 ~ 65535, 28673*
Common Address	1* ~ 65535
Upload Virtual SOE	Disable*, Enable
Upload AI Change	Disable, Enable*
Energy Upload Interval (s)	0* ~ 60000, 0 indicates no data upload.
AI Upload Interval (s)	0* ~ 60000, 0 indicates no data upload.
Idle Timeout(min)	Define the maximum duration of inactivity after which the connection will be automatically terminated. 1 ~ 60min, 5*
Data Upload Delay after Restart (s)	After the gateway is reset, it begins to collect and upload IEDs' data to the platform, which will take approximately 2 seconds. During this period, the data sent by the gateway to the platform may be invalid values. Setting this parameter to give the gateway sufficient time to collect valid data from the IEDs and avoid uploading invalid data. 0* ~ 300s
Remote Time Sync	On*, Off Enable/Disable IEC 104 Time Synchronization Command Execution.

Table 4-13 IEC104 Client Protocol

The screenshot displays the configuration interface for the IEC104 Client Protocol, divided into two main sections: Basic and Advanced.

Basic Configuration:

- Enable:** Checked (indicated by a green checkmark).
- Description:** Data Cache 1
- Main Station Address:** (Empty text field)
- Main Station Port:** 10000
- Backup Station Address:** (Empty text field)
- Backup Station Port:** 10000
- Login Packet:** (Empty text field)
- Heartbeat Interval(s):** 0
- Heartbeat Packet:** (Empty text field)
- KeepAlive Interval(s):** 0

Advanced Configuration:

- Number of Common Address Bytes:** 2
- Number of Transmission Reason Bytes:** 2
- Number of Information Object Bytes:** 3
- AI Start Address:** 16385
- AI Upload Type:** ASDU13
- DI Start Address:** 1
- DI Upload Type:** ASDU1
- Energy Start Address:** 25601
- Energy Upload Type:** ASDU15
- SOE Start Address:** 1
- SOE Upload Type:** ASDU30
- DO Start Address:** 24577
- AO Start Address:** 28673
- Common Address:** 1
- Upload Virtual SOE:** (Unchecked)
- Upload AI Change:** Checked (indicated by a green checkmark)
- Energy Upload Interval(s):** 0
- AI Upload Interval(s):** 0
- Idle Timeout(min):** 5
- Data Upload Delay after Restart(s):** 0
- Remote Time Sync:** On
- Remark:** (Empty text field)

Figure 4-31 IEC104 Client Protocol

Parameter	Range/Option, Default*
Basic	
Main Station Address	The connected master station address. Users can set LAN IP address, fixed public IP address, or dynamic/static domain name address.
Main Station Port	The port number of the master station server. 10000*
Backup Station Address	Reserved
Backup Station Port	Reserved
Login Packet	iSmartGate SE sends data packets when it is actively connecting to the server. These packets can uniquely identify the data packets of a gateway.
Heartbeat Interval (s)	The interval of sending a heartbeat packet. 0* ~ 60000. 0 means do not send a heartbeat packet.
Heartbeat Packet	A custom hexadecimal packet sent by the gateway to the master periodically to maintain an active connection and prevent timeout disconnection due to inactivity. Up to 63 bytes of 16 decimal characters (00~FF) can be configured. Null (Do not send a heartbeat packet).
KeepAlive Interval (s)	A parameter used in network communication (especially in protocols like TCP, MQTT, and HTTP) to maintain persistent connections by periodically sending small packets to prevent timeouts.
Advanced (Please refer to advanced IEC104 Client Protocol)	

Table 4-14 IEC104 Client Protocol

4.6.1.3 CET Modbus TCP Protocol

When set Protocol to CET TCP Client Protocol:

The screenshot displays the configuration interface for the CET Modbus TCP Protocol, divided into two main sections: Basic and Advanced.

Basic Section:

- Enable:** A checkbox that is currently unchecked.
- Description:** A text input field containing "Data Cache 1".
- Port:** A numeric input field with a value of 2001, flanked by minus and plus buttons.
- Client IP 1 through Client IP 16:** A vertical list of 16 empty text input fields for specifying client IP addresses.
- Storage Intervals:** A dropdown menu currently set to "5min".

Advanced Section:

- Retain Data on Comm Loss:** A checkbox that is currently unchecked.
- Idle Timeout(min):** A numeric input field with a value of 5, flanked by minus and plus buttons.
- Unit ID:** A numeric input field with a value of 255, flanked by minus and plus buttons.
- Dual-Active:** A checkbox that is currently unchecked.
- Ethernet List:** A text input field containing "ETH1".
- Data Upload Delay after Restart(s):** A numeric input field with a value of 0, flanked by minus and plus buttons.
- Storage Method during Failure:** A dropdown menu currently set to "Store Invalid Value".
- Remark:** An empty text input field.

Figure 4- 32 CET Modbus TCP Protocol

Parameter	Range/Option, Default*
Basic	
Port	In scenarios where multiple remote stations access the iSmartGate SE's cache channels, it is imperative that the Master Station IP and Port are configured to differentiate between them. In the event of the same port being required for different cache channels, it is necessary to set different Master Station IPs in order to distinguish between them. A cache channel should be uniquely determined by: Port + Master Station IP. 1 ~ 65535, 2001* for cache channel 1 and 2002* for cache channel 2
Client IP 1~16	The Client IP 1~16 are the IP addresses of the remote stations and only the specified stations are able to retrieve data from iSmartGate SE's cache channels. Setting the Client IP 1~16 as null allows any stations to retrieve data from iSmartGate SE's cache channels.
Storage Intervals	Off/1/5*/10/15/20/30/60 min
Advanced	
Retain Data on Comm Loss	Checking this box means retaining data upload prior to the communication failure. Unchecking the box will upload invalid values.
Idle Timeout(min)	Defines the maximum duration of inactivity after which the connection will be automatically terminated. 1 ~ 60min, 5*
Unit ID	Specifies the Comm. ID of the gateway during systems collecting data based on Modbus TCP protocol. 1 ~ 255*
Dual-Active (Reserved)	Disable*, Enable
Ethernet List (Reserved)	ETH1*
Data Upload Delay after Restart(s)	After the gateway is reset, it begins to collect and upload IEDs' data to the platform, which will take approximately 2 seconds. During this period, the data sent by the gateway to the platform may be invalid values. Setting this parameter to give the gateway sufficient time to collect valid data from the IEDs and avoid uploading invalid data. 0* ~ 300s
Storage Method during Failure	Specifies historical data storage mode after a communication interruption. Store Invalid Value*, Retain the Last Valid Value

Table 4-10 CET Modbus TCP Protocol

4.6.1.4 IoT MQTT+JSON Protocol

When set Protocol to IoT MQTT+JSON Protocol:

Figure 4- 33 Parameters for the MQTT Protocol

Parameter	Range/Option, Default*
Basic	
Main Station Address	The connected master station address. Users can set LAN IP address, fixed public IP address, or dynamic/static domain name address.
Main Station Port	The port number of the master station server. 10000*
Backup Station Address	Reserved
Backup Station Port	Reserved

Storage Intervals	Specifies storing log interval. 1min, 5min*, 10min, 15min, 20min, 30min, 60min, Off The system can store data for 15 days @ 1-minute interval and for 900 days @ 60-minute interval.
Scheduled Upload Interval(s)	In general, the automatic upload interval of the gateway should be consistent with the Storage Interval when the former is set to 1 minute or longer. It is not recommended to set the data upload interval to less than 10 seconds, as this may lead to data congestion. 10 - 65535, 300*
Username	The username for the MQTT or EMQX server, provided by the master station.
Password	The password for the MQTT or EMQX server, provided by the master station.
Product Key	Corresponds to the "pKey" field in the JSON messages.
Gateway SN	A number that can be used to uniquely identify the gateway. It is recommended to use the gateway SN, which corresponds to the SN in the JSON message.
Gateway Name	IoT Gateway Name
Manufacturer ID	Enter according to master station requirements (optional).
Advanced	
TLS Encryption	Enable Transport Layer Security (TLS) Encryption.
Upload TLS Certificate	<ul style="list-style-type: none"> ○ No encryption (plaintext communication): Uncheck the TLS Encryption box ○ Server-side TLS only: Check the TLS Encryption box but do not upload TLS Certificate ○ Mutual TLS (mTLS) authentication: Check the TLS Encryption box and upload three Certificates Click Select File to upload certificates. Note: Only one Certificate can be uploaded at a time.
Idle Timeout (min)	The connection will be closed if there is no activities between the serial ports in the specified time. 1 ~ 60min, 5min*
DI Upload Mode	<ul style="list-style-type: none"> ○ On-change+Scheduled Upload * ○ Scheduled Upload ○ On-change Upload
AI Change Upload	Enable uploading AI Change Disable*, Enable
Time Sync Timeout (min)	When the time difference between the platform's synchronization command and the gateway's local clock exceeds configured value, the time calibration will be rejected. 0 means fully time synchronization by the platform. 0* ~ 600min
Data Upload Delay after Restart(s)	After the gateway is reset, it begins to collect and upload IEDs' data to the platform, which will take approximately 2 seconds. During this period, the data sent by the gateway to the platform may be invalid values. Setting this parameter to allow the gateway sufficient time to collect data from the IEDs and avoid uploading invalid data. 0* ~ 300s
KeepAlive Interval(s)	A parameter used in network communication (especially in protocols like TCP, MQTT, and HTTP) to maintain persistent connections by periodically sending small packets to prevent timeouts. 0~60000s, 20*
Storage Method during Failure	Specifies historical data storage mode after a communication interruption. Store Invalid Value*, Retain the Last Valid Value

Table 4-15 Parameters for the MQTT

4.6.1.5 Aliyun MQTT ALINK JSON Protocol

When set Protocol to Aliyun MQTT ALINK JSON Protocol:

The image shows a configuration interface for the Aliyun MQTT ALINK JSON Protocol, divided into two sections: Basic and Advanced.

Basic Section:

- Enable:**
- Description:** Data Cache 1
- Main Station Address:** [Empty text field]
- Main Station Port:** 10000
- Backup Station Address:** [Empty text field]
- Backup Station Port:** 10000
- Storage Intervals:** 5min

Advanced Section:

- Gateway Name:** [Empty text field]
- Gateway Key:** [Empty text field]
- GateWay Secert Key:** [Empty text field]
- Gateway ID:** [Empty text field]
- Region ID:** [Empty text field]
- Power Loss Alarm:**
- Resume from BreakUp:**
- DI Change Upload:**
- AI Change Upload:**
- Topic Type:** Thing topic
- Extended Parameter 1:** [Empty text field]
- Extended Parameter 2:** [Empty text field]
- Extended Parameter 3:** [Empty text field]
- Extended Parameter 4:** [Empty text field]
- Extended Parameter 5:** [Empty text field]
- Extended Parameter 6:** [Empty text field]
- Extended Parameter 7:** [Empty text field]
- Extended Parameter 8:** [Empty text field]
- Extended Parameter 9:** [Empty text field]
- Storage Method during Failure:** Store Invalid Value

Figure 4- 34 AliyunMQTT

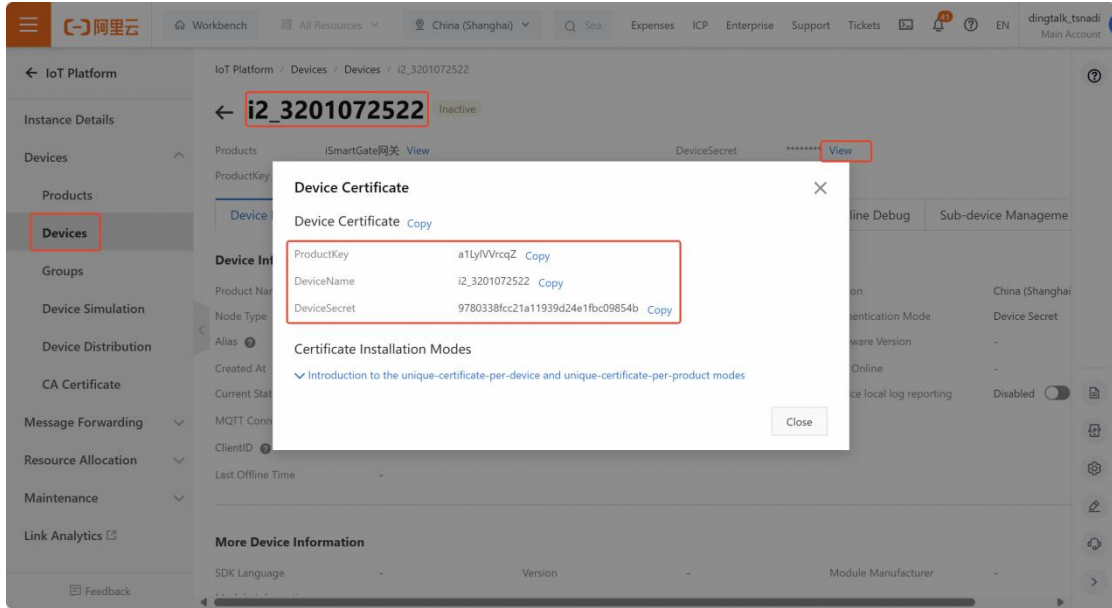

Figure 4- 35 Alibaba Cloud IoT Platform

Parameter	Range/Option, Default*
Basic	
Main Station Address	The connected master station address. Users can set LAN IP address, fixed public IP address, or dynamic/static domain name address.
Main Station Port	The port number of the master station server. 10000*
Backup station Address	Reserved
Backup Station Port	Reserved
Storage Intervals	Specifies storing log interval. Scheduled Upload Interval=Storage Intervals. 1min, 5min*, 10min, 15min, 20min, 30min, 60min, Off The system can store data for 15 days @ 1-minute interval and for 900 days@ 60-minute interval.
Advanced	
Gateway Name	Corresponds to the DeviceName in the Alibaba Cloud (IoT Platform > Devices > Devices > The Gateway).
Gateway Key	Corresponds to the ProductKey in the Alibaba Cloud (IoT Platform > Devices > Devices > The Gateway).
Gateway Secret Key	Corresponds to the DeviceSecret in the Alibaba Cloud (IoT Platform > Devices > Devices > The Gateway).
Gateway ID	Parameter Requirement: Must be unique. It is recommended to fill in the gateway's factory serial number (SN).
Region ID	Optional and configure this parameter only it is required by the Alibaba Cloud Platform.
Power Loss Alarm	Disable*, Enable
Resume from BreakUp	Disable, Enable*
DI Change Upload	Disable*, Enable
AI Change Upload	Enable uploading changed Analog Value Disable*, Enable
Topic Type	Thing topic* (Preferred) Customization topic Please contact CET before resetting the parameter to Customization topic .
Extended Parameter 1-9	Reserved
Storage Method during Failure	Specifies historical data storage mode after a communication interruption. Store Invalid Value*, Retain the Last Valid Value

Table 4-16 Parameters for the AliyunMQTT Protocol

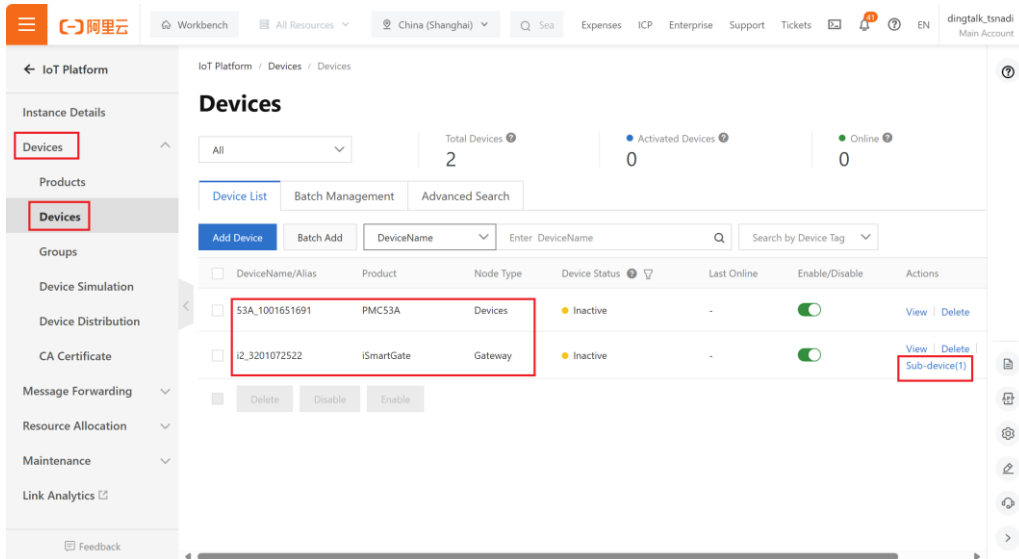

Figure 4- 36 Alibaba Cloud IoT Platform

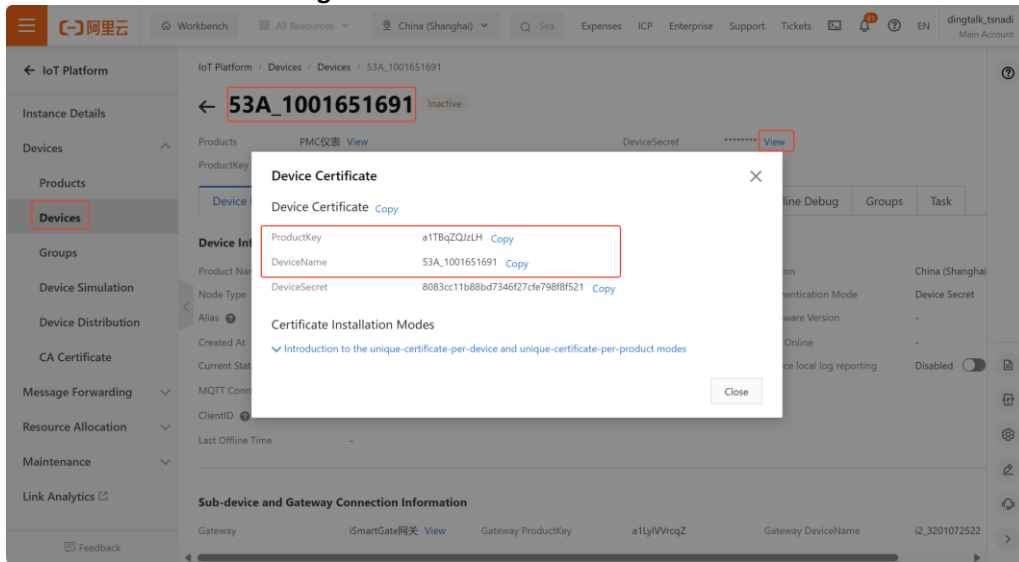

Figure 4- 37 Alibaba Cloud IoT Platform of IED/Sub-device

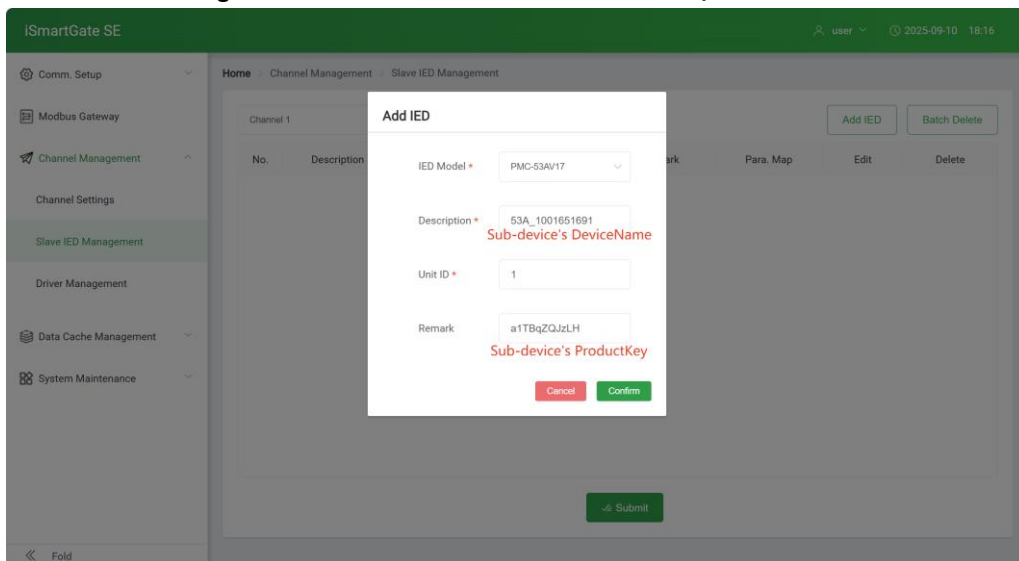

Figure 4- 38 Sub-device's DeviceName and ProductKey

On the Alibaba Cloud platform, the **DeviceName** and **ProductKey** of the sub-device must be configured in the **Slave IED Management** interface of the iSmartGate SE.

- The **Description** field in the Slave IED Management interface corresponds to the **DeviceName** of the sub-device on Alibaba Cloud.
- The **Remark** field in the Slave IED Management interface corresponds to the **ProductKey** of the sub-device on Alibaba Cloud.

4.6.1.6 BACnet/IP Protocol

When set **Protocol** to **BACnet/IP Protocol**:

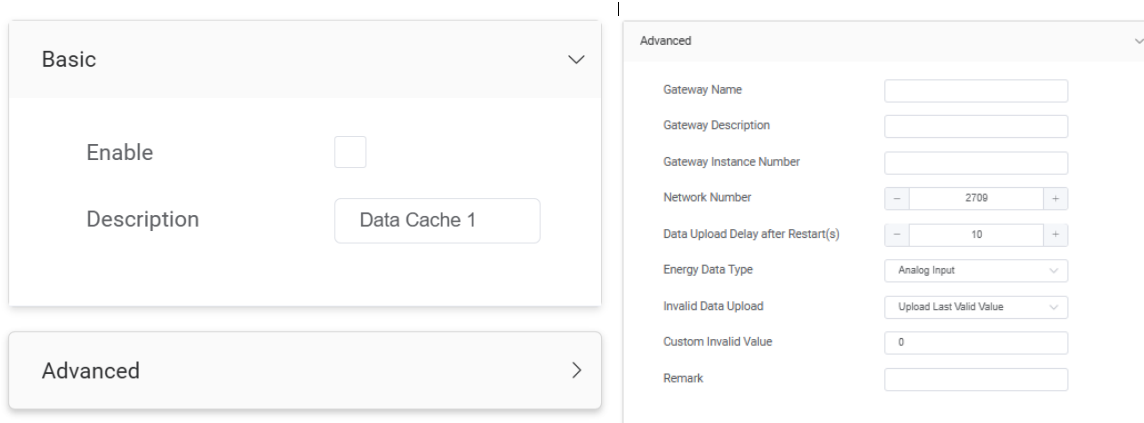

Figure 4-39 BACnet/IP

Parameter	Range/Option, Default*
Gateway Name	Gateway name.
Gateway Description	The gateway itself also functions as a BACnet/IP device. Describe the gateway based on on-site requirements via this parameter.
Gateway Instance Number	The Device ID of the gateway which is a unique number that identifies a gateway. It is recommended to use the gateway's serial number.
Network Number	Network Number for IEDs that are connected to the Gateway. 1 ~ 65534, 2709*
Data Upload Delay after Restart (s)	After the gateway is reset, it begins to collect and upload IEDs' data to the platform, which will take approximately 2 seconds. During this period, the data sent by the gateway to the platform may be invalid values. Setting this parameter to allow the gateway sufficient time to collect data from the IEDs and avoid uploading invalid data. 0 ~ 300s, 10*
Energy Data Type	Analog Input*, Accumulator
Invalid Data Upload	Upload Last Valid Value* or Custom Invalid Value
Custom Invalid Value	Only valid when Invalid Data Upload is set to Custom Invalid Value.

Table 4-17 BACnet/IP

Note: The IED's Instance Number of **BACnet/IP Protocol** can be set in the **Remark** of the **Slave IED Management**, as shown in the figure below.

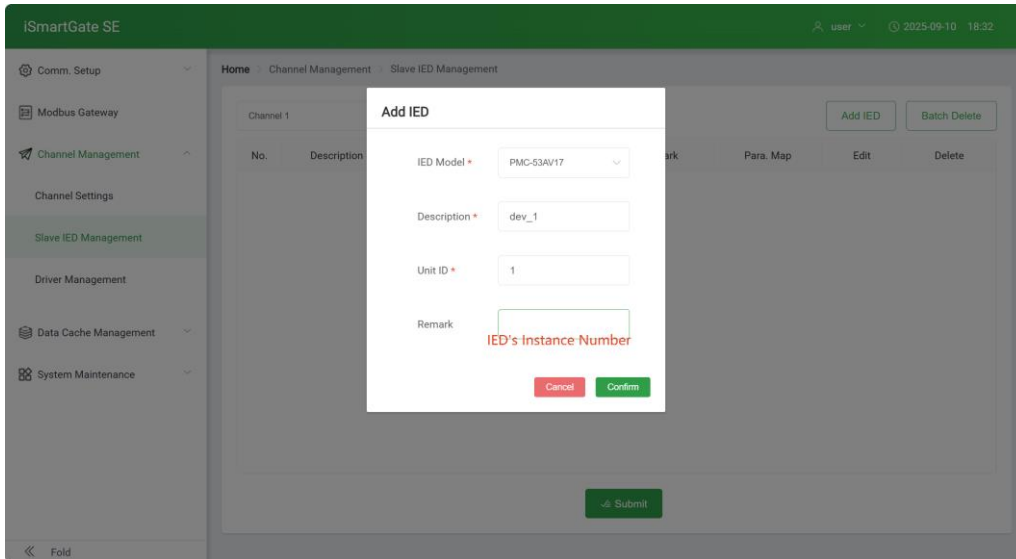

Figure 4-40 IED's Instance Number

4.6.1.7 Custom Http+Json Protocol

It is recommended to set parameters for the **Custom Http+Json Protocol** via the **PMC-EasyCom** configuration software as not all parameters can be configured via the web interface

4.6.2 Data Cache

Click **Data Cache** on the left-hand pane and the following screen appears. Click data cache drop-down box to select the data cache to add parameters or delete parameters.

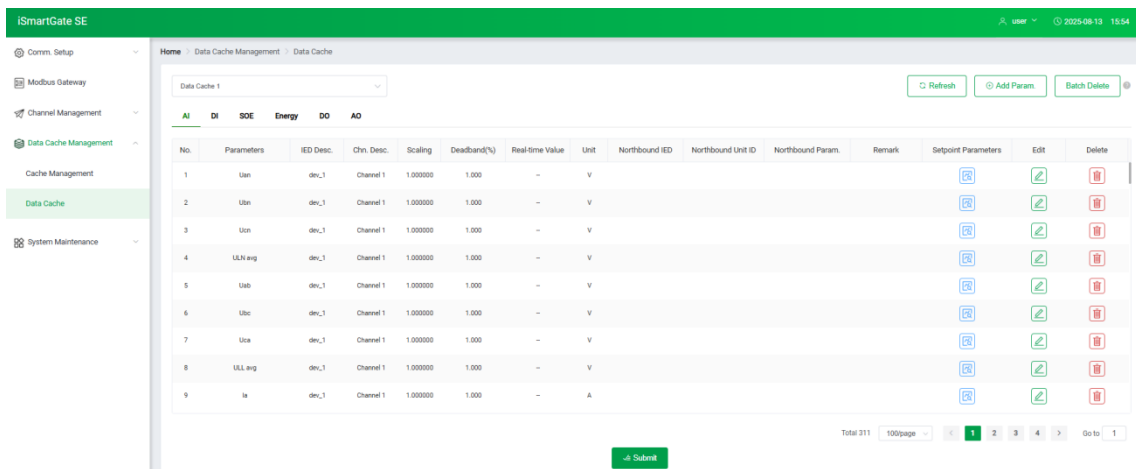

Figure 4-41 Data Cache

Click **Add Param.**, then select the required measurement points in the pop-up dialog box. Users can select parameters in batches to add to the **Added Parameters** area, and then click **Confirm**.

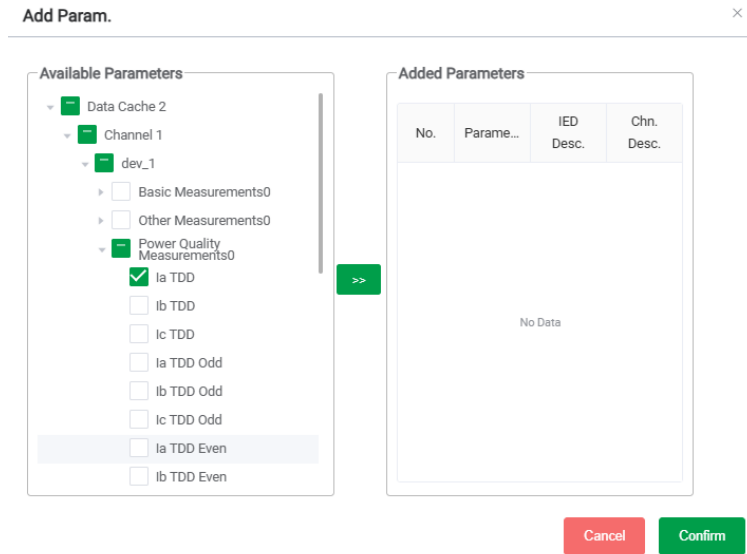

Figure 4-42 Add Param.

Add DI, SOE, Energy, DO, and AO parameters similarly.

4.7 System Maintenance

Click **System Maintenance** on the left-hand pane and its sub-menus appears which includes **Password Setup, Network Detection, Time Setting, System Information, SOE Log, Device Log, Clear History Data, Upgrade, Backup/Restore** and **Reboot**. The following sections provide a quick overview for these sub-menus.

4.7.1 Password Reset

Click **Password Reset** on the left-hand pane and the following screen appears on the right-hand pane, which allows users to change password for the “user”. The original password is "123456".

Enter the new password twice and click **Submit** to save your changes.

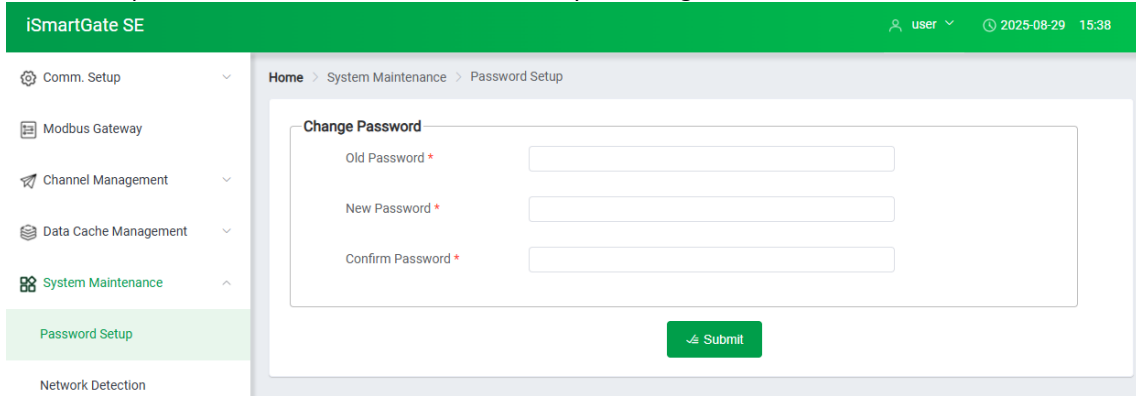



Figure 4- 43 Reset Password Screen

4.7.2 Network Detection

Click **Network Detection** on the left-hand pane and the following screen appears on the right-hand pane which allows users to test the network access for the iSmartGate SE and connected devices. If the network access is abnormal, users can monitor message and export packet file to locate fault.

Packet Capture:

1. Select **Interface** type (**4G** or **ETH**) from drop-down box.
2. Select **Packet Capture Max Value** (5MB or 10MB) from the drop-down box.
3. Click **Start** to capture packet and click **Stop & Save** to save the captured packet

For example:  eth0_20250813_082347.pcap.gz

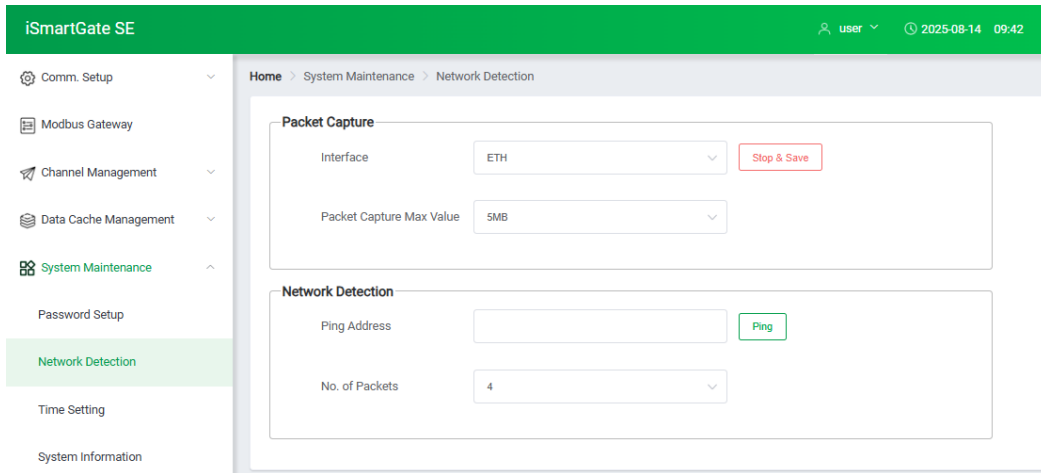

Figure 4- 44 Packet Capture Screen

4. Open the exported file via Wireshark and check the fault cause.

Network Detection:

Enter a destination IP address and click **Ping**, and the detection result will be displayed.

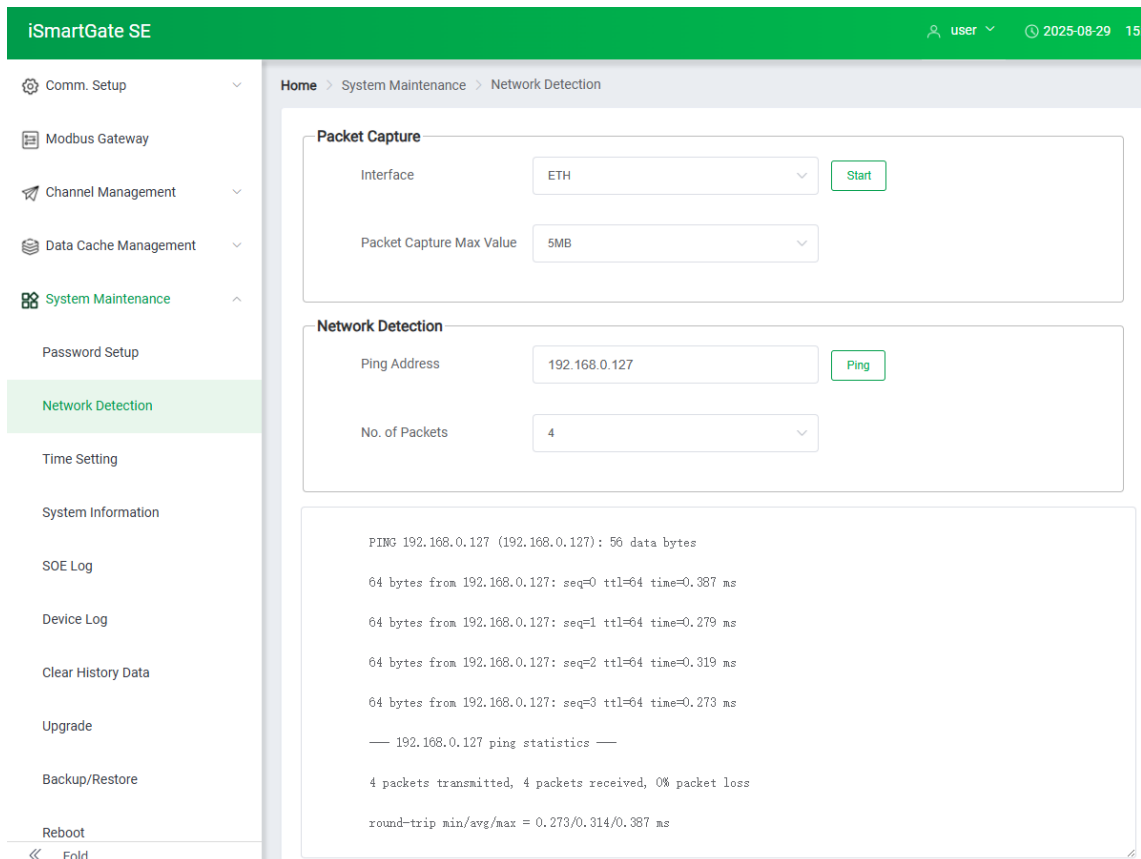

Figure 4-45 Network Detection Screen

4.7.3 Time Settings

Click **Time Setting** on the left-hand pane and the following screen appears on the right-hand pane. Users can setup date and time via setup **Device Clock** and **Device Time** areas. Besides, users can synchronize the device time with the PC by simple checking **Sync. PC Clock** box.

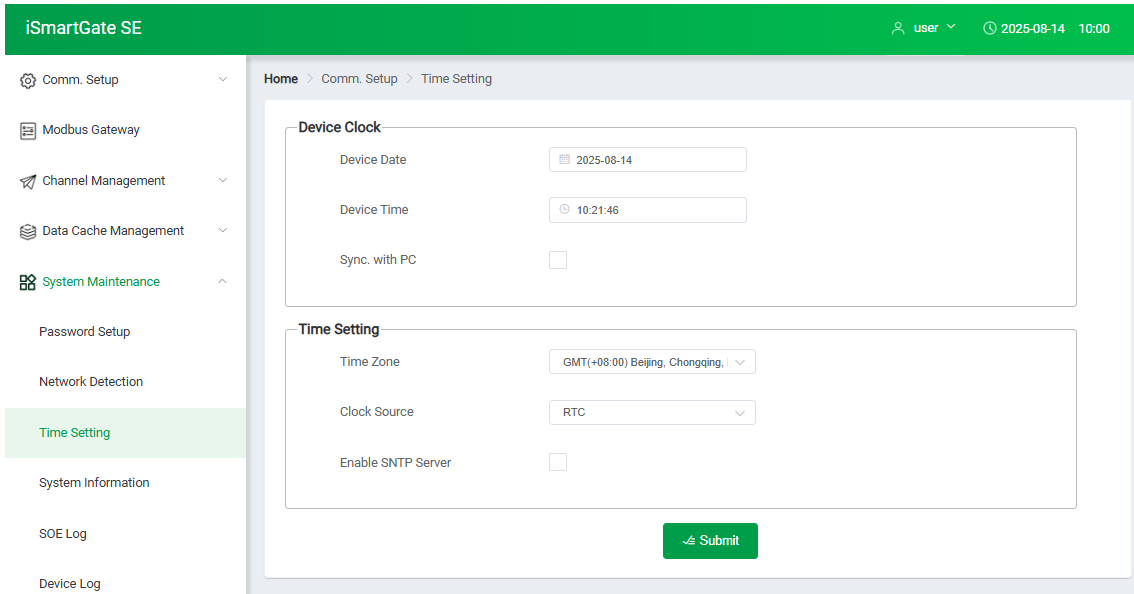

Figure 4-46 Time Setting Screen-Device Clock

The iSmartGate SE supports **RTC** and **SNTP** time synchronization modes.

RTC:

The iSmartGate SE is equipped with a 6ppm, battery-backed real-time clock that has a maximum error of 0.5s per day. If the supply power is lost or removed, the internal back-up battery keeps the real-time clock running until power is restored. The **Clock Source** is set to **RTC** by default and users can change it via the web.

SNTP:

SNTP (Simple Network Time Protocol) can be used to synchronize the iSmartGate SE's clock with an external **SNTP Server** through its Ethernet port providing that the network has been properly configured. Additionally, if the device is equipped with 4G option and the 4G supports public mobile network, the iSmartGate SE's clock can be synchronized with an external SNTP server via the 4G connection.

Parameters	Options/Range	Default Setting
Time Zone	GMT-12:00/GMT-11:00/GMT-10:00/GMT-9:00/GMT-8:00/GMT-7:00/GMT-6:00/GMT-5:00/GMT-4:00/GMT-3:30/GMT-3:00/GMT-2:00/GMT-1:00/GMT-0:00/GMT+1:00/GMT+2:00/GMT+3:00/GMT+3:30/GMT+4:00/GMT+4:30/GMT+5:00/GMT+5:30/GMT+5:45/GMT+6:00/GMT+6:30/GMT+7:00/GMT+8:00/GMT+9:00/GMT+9:30/GMT+10:00/GMT+11:00/GMT+12:00/GMT+13:00	GMT+8:00
Clock Source	RTC, SNTP	RTC
SNTP Address	Set the IP address of the SNTP Server .	

Table 4-18 Time Setting Parameters

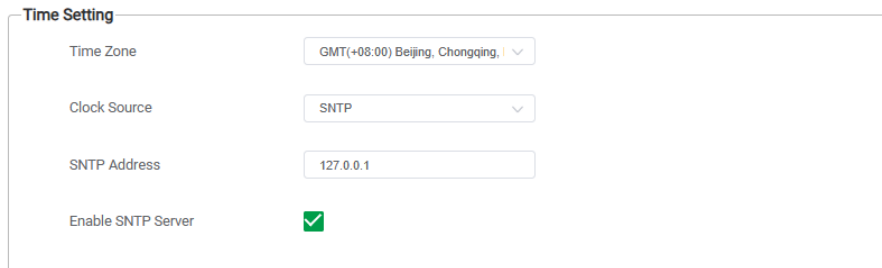

Figure 4-47 Time Setting Screen

In addition, the iSmartGate SE can serve as a SNTP server for the download Ethernet IED's to synchronize time.

4.7.4 System Information

Click **System Information** on the left-hand pane and the following screen appears on the right-hand pane where displays the iSmartGate SE model and basic configuration information, including device name, description, firmware, firmware date, S/N and MAC1.

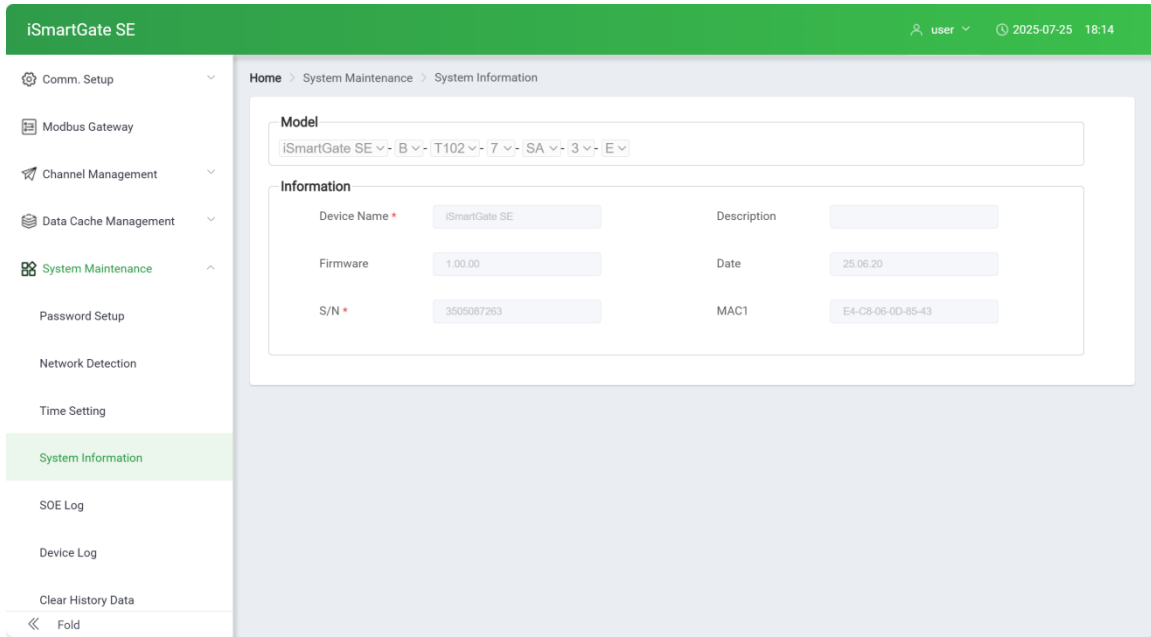

Figure 4- 48 System Information

4.7.5 SOE Log

Click **SOE Log** on the left-hand pane to display the SOE Log on the right-hand pane starting with the most recent events. The interface supports the following filtering mechanism.

Event Type: Use the drop-down box on the left to select a particular event type, including **All SOE**, **Operations** and **Self-diagnostics**.

Search Period: You can click **Last Day**, **Last Week**, **Last Month**, **Last Three Months** or select a specific period.

Search Period	2025 August	2025 September
Last Day	1	1
Last Week	27, 28, 29, 30, 31, 1, 2	31, 1, 2, 3, 4, 5, 6
Last Month	3, 4, 5, 6, 7, 8, 9	7, 8, 9, 10, 11, 12, 13
Last Three Months	10, 11, 12, 13, 14, 15, 16	14, 15, 16, 17, 18, 19, 20
	17, 18, 19, 20, 21, 22, 23	21, 22, 23, 24, 25, 26, 27
	24, 25, 26, 27, 28, 29, 30	28, 29, 30, 1, 2, 3, 4
	31, 1, 2, 3, 4, 5, 6	5, 6, 7, 8, 9, 10, 11

The **Previous Period** and **Next Period** will be previous or next time range same period depending on the **Search Period**. For example, if the **Search Period** is set to **Last Week**, click **Previous Period** will display SOE logs of the week before last. And there will be no logs for the **Next Period**.

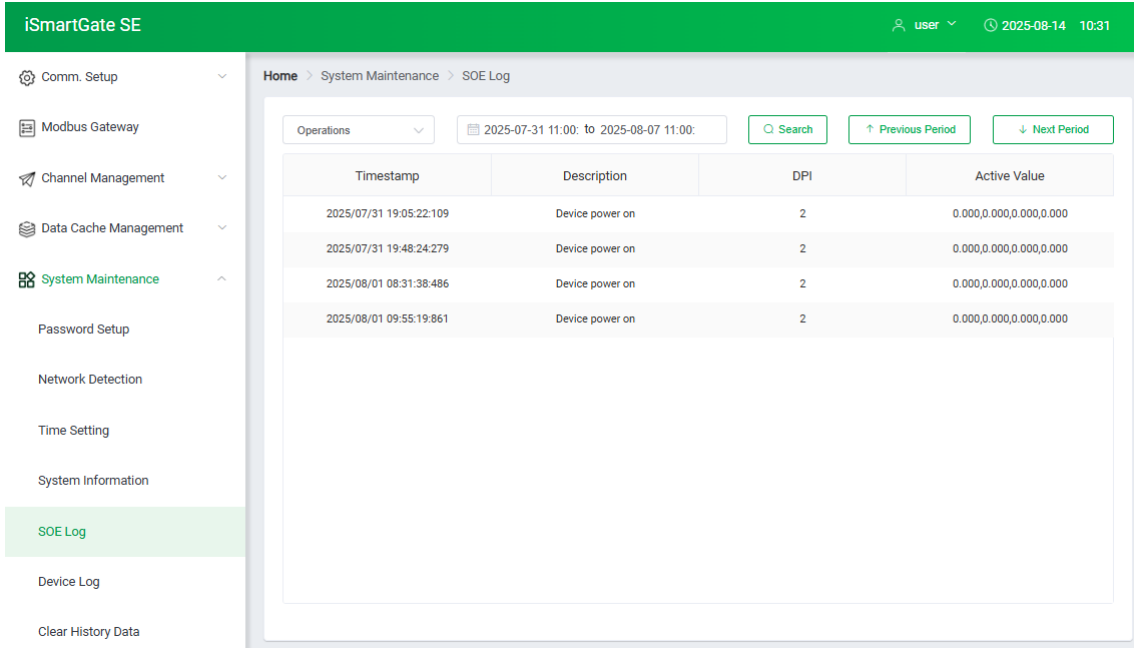

Figure 4-49 SOE Log

4.7.6 Device Log

Click **Device Log** on the left-hand pane and the following screen appears on the right-hand pane starting with the most recent events. The device logs will help to identify of faults when the iSmartGate SE malfunctions. Click **Clear Log** to clear device logs and click **Export Log** to download the current page’s device logs.

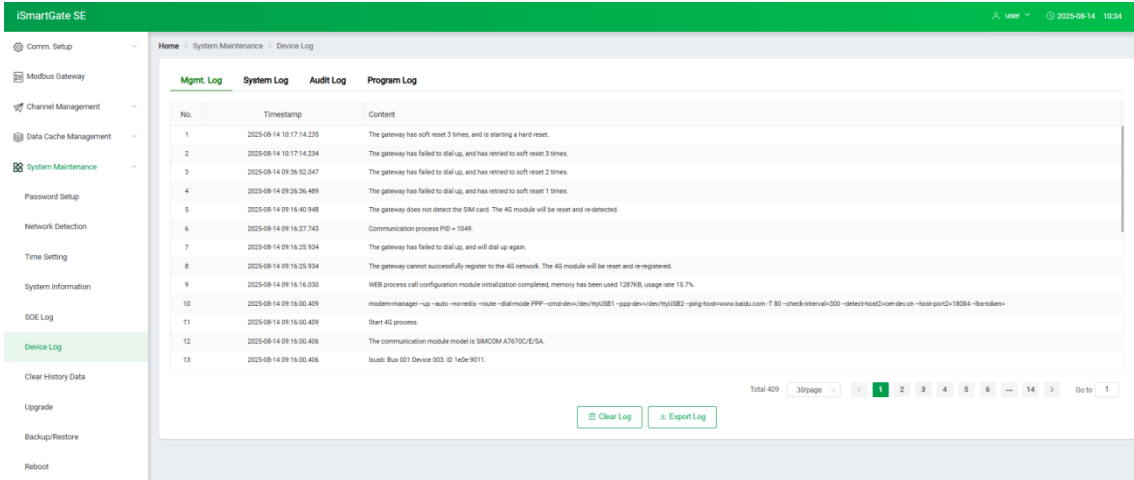

Figure 4-50 Device Log Screen

4.7.7 Clear History Data

Click **Clear History Data** on the left-hand pane and the following screen appears on the right-hand pane to clear data records and historical SOE logs.

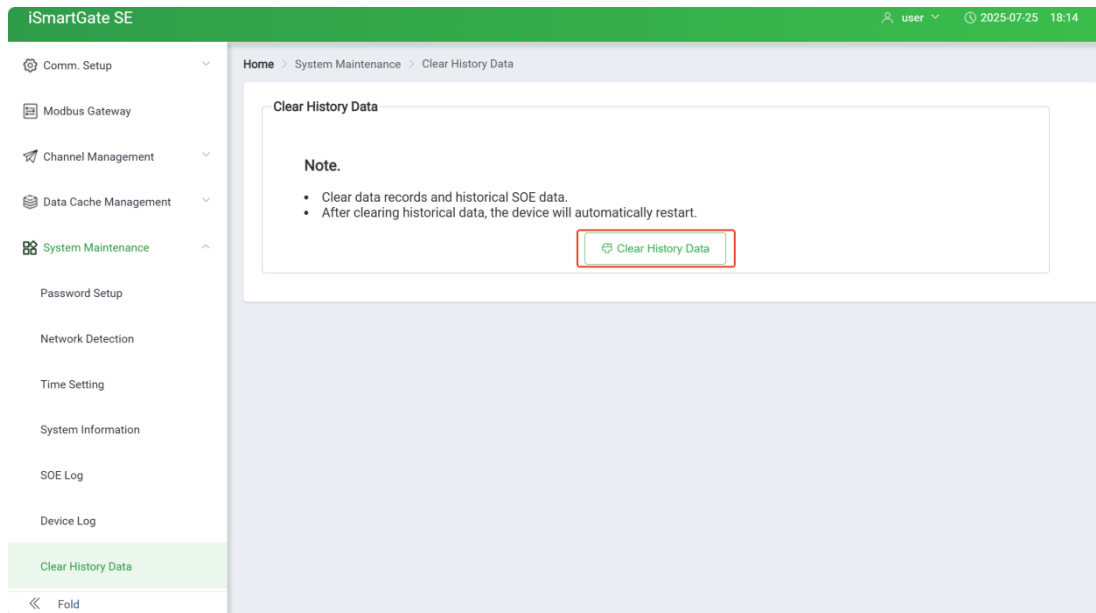

Figure 4-51 Clear History Data Screen

4.7.8 Upgrade

Click **Upgrade** on the left-hand pane to upgrade web program online.

1. Click **Upgrade** on the right-hand pane.
2. Drag upgrade files or click to select upgrade files to the **Add Upgrade Package** dialog box.

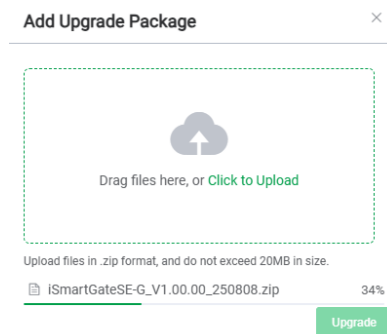

Figure 4-52 Add Upgrade Package Dialog

3. After uploading the upgrade file, click **Upgrade**.
4. Wait for upgrading and then reboot the device.

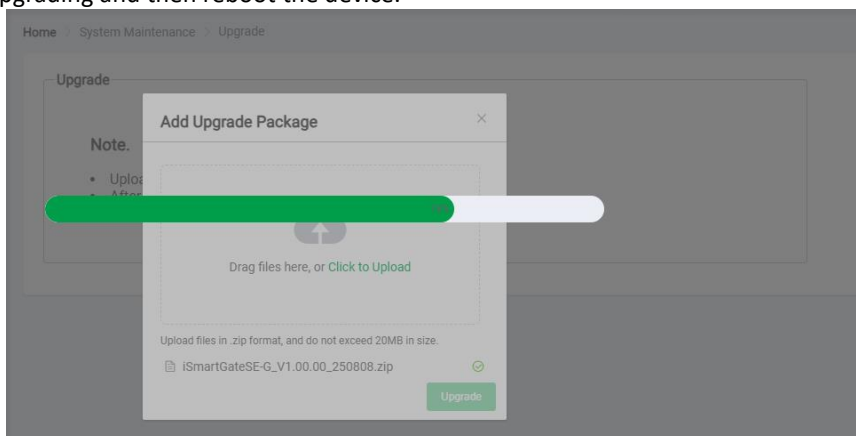

Figure 4-53 Upgrade Screen

4.7.9 Backup/Restore

Click **Backup/Restore** on the left-hand pane and the following page are shown in the right pane.

Backup: click **Export Config** to export device configuration file to local PC.

Restore: click **Select Config** to select the configuration file and click **Restore Config** to reset the iSmartGate SE to the specific configuration.

Restore Factory Defaults: allows users to reset the iSmartGate SE to the factory default configuration.

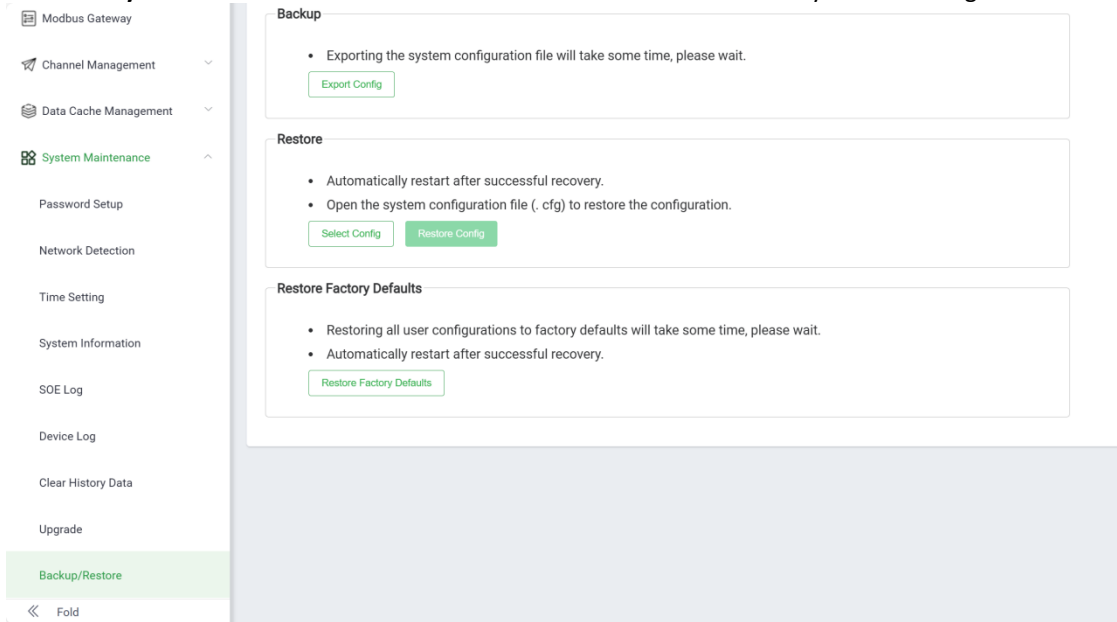

Figure 4-54 Backup/Restore Screen

4.7.10 Reboot

Configuration changes will not take effect until the **Reboot** operation has been executed. Click **Reboot** on the left-hand pane and the following screen appears on the right-hand pane. Click the **Reboot** button to initiate the restart sequence. After restart, the user needs to log in again to access to the iSmartGate SE Web.

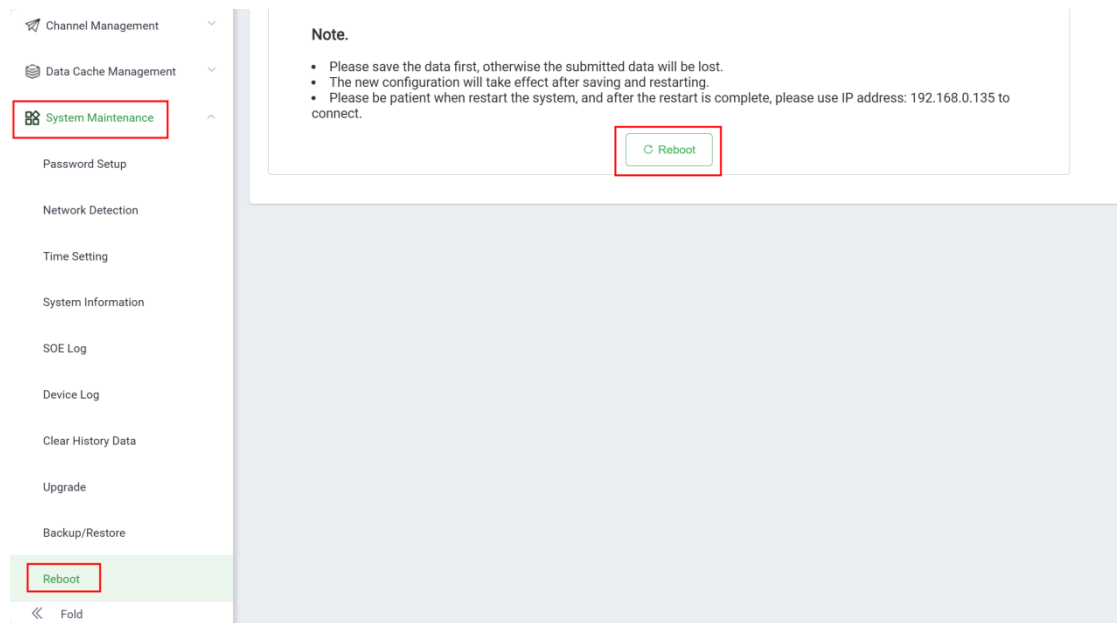

Figure 4-55 Reboot Screen

Chapter 5 Applications

The iSmartGate SE enables efficient transfer of serial packets between upstream network - based applications and downstream RS-485 or optional LoRa wireless devices through a TCP/IP connection.

Traditional methods often involve using a Windows - based “Virtual COM” driver along with a port - mapping utility. However, this approach frequently encounters driver incompatibility issues across various Windows versions. In contrast, the iSmartGate SE allows applications to directly connect to it via TCP/IP. This enables transparent transfer of serial packets within TCP/IP frames to and from downstream devices.

The iSmartGate SE is ideally suited for communicating with industrial devices featuring timing - sensitive protocols. It offers a reliable interface for SCADA or similar applications. These applications, which already support direct connection with an Ethernet Gateway, can communicate with serial devices regardless of the protocols used.

Moreover, the iSmartGate SE supports the Modbus TCP to Modbus RTU Gateway function. This function simplifies the process for any Modbus TCP Master applications to interface with Modbus RTU - enabled IEDs over a local area network. A user - friendly web - based interface allows easy configuration of the TCP to RTU address mapping for downstream Slave IEDs connected via RS-485, Ethernet or optional LoRa.

The iSmartGate SE can be configured to support multiple Masters. This not only facilitates information sharing but also minimizes implementation costs. Additionally, the optional LoRa port supports configurable ISM Bands, making it suitable for wireless IoT applications in most countries.

The following figure illustrates a typical application scenario for the iSmartGate SE.

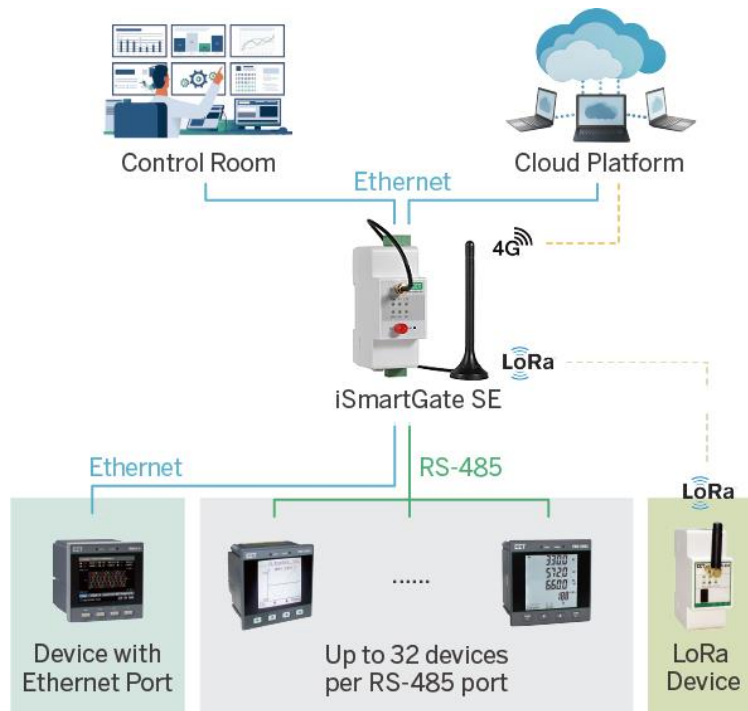

Figure 5-1 Typical Application

5.1 Transparent Gateway

The iSmartGate SE supports the efficient transfer of serial packets between the upstream network-based applications and the downstream RS-485/LoRa devices via a TCP/IP connection.

The Transparent Gateway function on the iSmartGate SE supports two modes: TCP Server and TCP Client.

5.1.1 TCP Server Mode

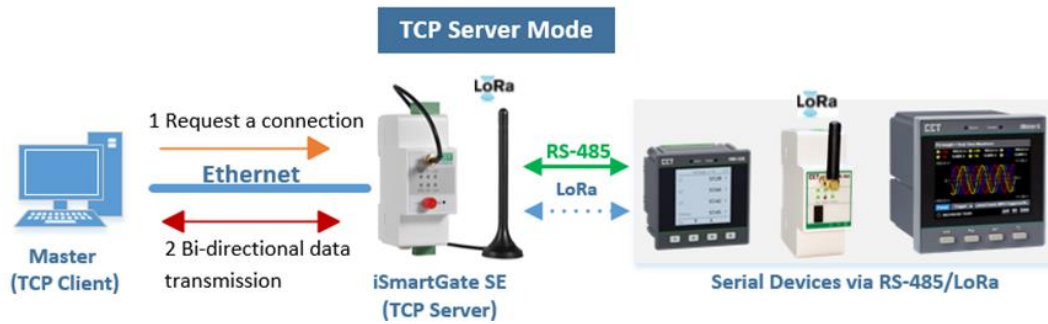

Figure 5-1 TCP Server Mode

The iSmartGate SE, which works in the TCP Server mode, will wait passively network connection requests from the Master via Ethernet, allowing the Master to establish a connection with and retrieve data from the downstream serial devices. The iSmartGate SE will listen on the local port set by the user and build a connection after receiving Master’s connection request. Data from the serial devices will be sent to the Master via the iSmartGate SE. As illustrated in the figure above, the process is as follows:

1. The Master requests a connection to the iSmartGate SE.
2. Once the connection is established, data can be transmitted between the Master and serial devices via the iSmartGate SE.

5.1.2 TCP Client Mode

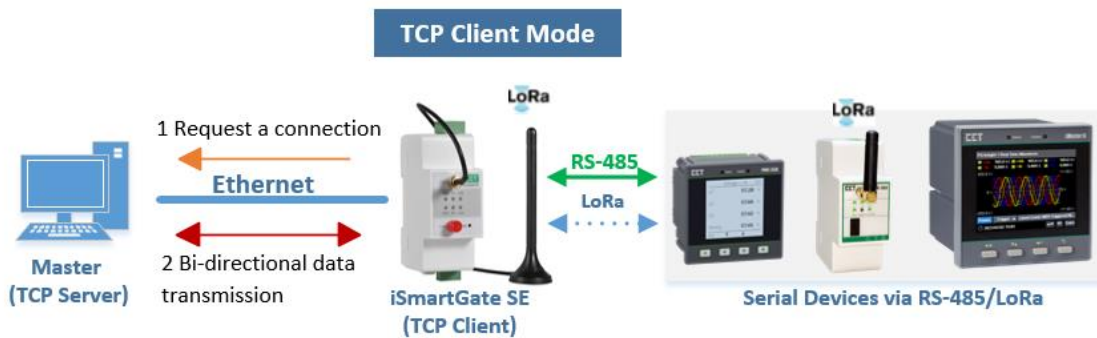

Figure 5-2 TCP Client Mode

The iSmartGate SE that works in the TCP Client mode will connect to the Master to enable data transmission between the serial devices and the Master. The iSmartGate SE can actively establish a TCP connection to the Master when serial data is received. As illustrated in the figure above, the process is as follows:

1. The iSmartGate SE requests a connection to the Master.
2. Once the connection is established, data can be transmitted between the Master and serial devices via the iSmartGate SE.

5.1.3 Multiple Masters

The iSmartGate SE supports Multiple-Master connections under Transparent Gateway to allow multiple network clients to send requests asynchronously. The gateway queues these requests and executes them sequentially on the RS-485 bus. For each request, it waits for the response for up to the Packet Timeout duration. After each transaction (whether a successful response or a timeout), the gateway enforces the Polling Delay. This mechanism ensures fair and stable access to the shared RS-485 bus for all network masters, preventing data corruption. The Multiple Masters function is disabled by default and can be enabled via the Web Console. A maximum of 4 Masters per RS-485/LoRa port can be connected.

1. Click **Modbus Gateway**.
2. Select **P1 (RS-485)**, **P2 (RS-485)** or **LoRa**. Here taking P1 as an example.
3. Set **Protocol** to **Transparent Gateway**.
4. Set **Multi Master** as **Enable** and click **Configure** to setup parameters including Polling Delay and Packet Timeout. Please refer to the **Section 4.4** for details.

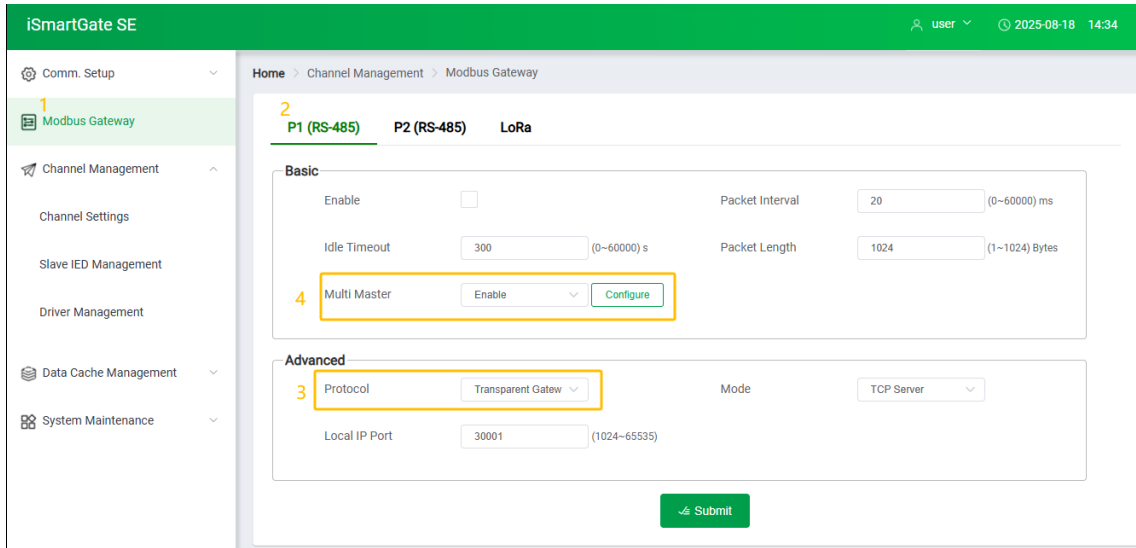

Figure 5-3 Multiple Masters Settings

5.2 Modbus Gateway

The iSmartGate SE provides the Modbus Gateway function that makes it extremely simple for any Modbus TCP Master applications to interface with slaves (Modbus RTU enabled IEDs) over a local area network.

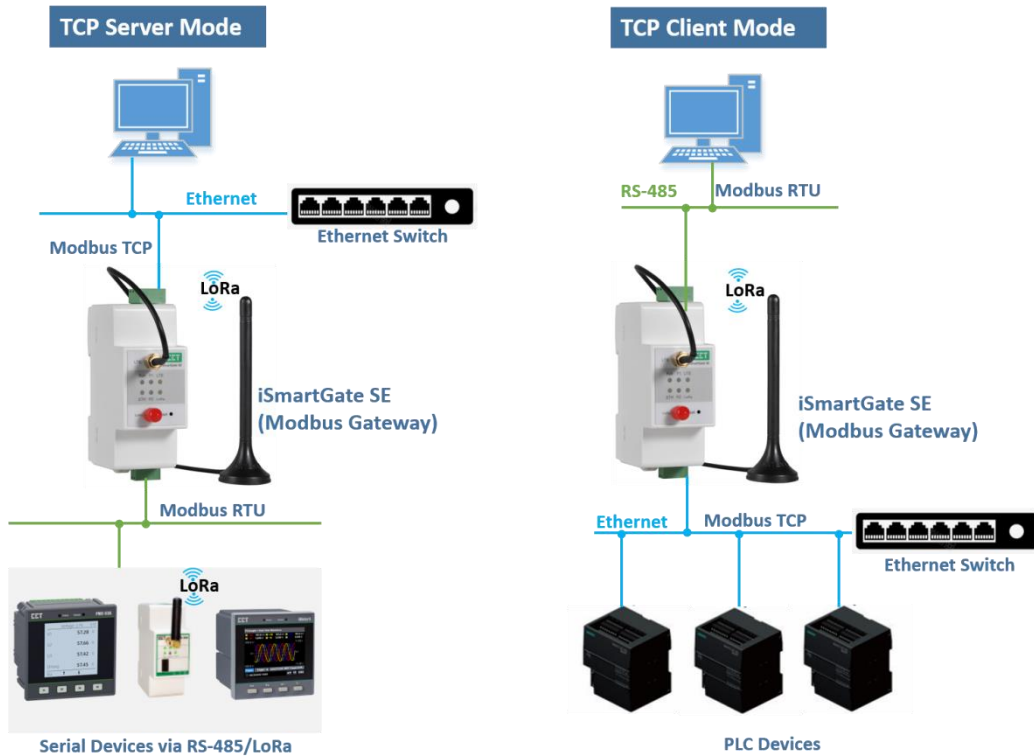

Figure 5-4 Modbus Gateway Function

The iSmartGate SE supports:

- TCP Server and TCP Client modes
 - TCP Server mode: The iSmartGate SE provides the master with **server** functionality via Modbus TCP through the Ethernet port .
 - TCP Client mode: The iSmartGate SE provides the master with **client** functionality via Modbus TCP through the Ethernet port.
- A maximum of 32 downstream LoRa devices per iSmartGate SE
- 32 Slave IEDs per RS-485 port
- A maximum of 4 Masters per RS-485/LoRa port

The following is the process flow:

1. Establish connection between the Master and the iSmartGate SE.
 - TCP Sever mode: The Master requests a connection to the iSmartGate SE.
 - TCP Client mode: The iSmartGate SE requests a connection to the Master.
2. After the connection is established, the Master sends TCP message to the iSmartGate SE.
3. iSmartGate SE converts the received RTU message to TCP format and sends it to the slaves.
4. The slaves returns a response (RTU message) to the iSmartGate SE.
5. The iSmartGate SE converts the RTU message to TCP format and returns it to the Master.

A simple web console allows users to easily configure the TCP to RTU address mapping for downstream Slave IEDs connected via RS-485/LoRa port. Please refer to **Section 4.5.2** for details.

5.3 Data Cache

With one Ethernet port and one built-in 4G modem, as well as extensive protocols support such as Modbus RTU, Modbus TCP, IEC 60870-5-104 (IEC 104), AnyPolling and optional BACnet/IP, etc., the iSmartGate SE supports pushing the following data to external: 4096xAI, 4096xDI, 2048xEnergy, 1024xAO, 1024xDO, 2048xSOE. In addition, it also supports resumable transfer for historical data. Please refer to **Section 4.6.2** for guidelines to manage pushed data.

Up to 2 Data Cache channels (Ethernet or 4G) can be configured. The detailed parameters are different based on selected protocols, please refer to **Section 4.6.1** for more information.

5.4 Data Collection and Management

The iSmartGate SE is capable of collecting data via 4 channels (Ethernet, RS-485 or LoRa) from maximum 128 downstream devices.

1. Click **Channel Management > Channel Settings** on the left-hand pane to setup 4 channels. Please refer to **4.5 4.5.1** for details.

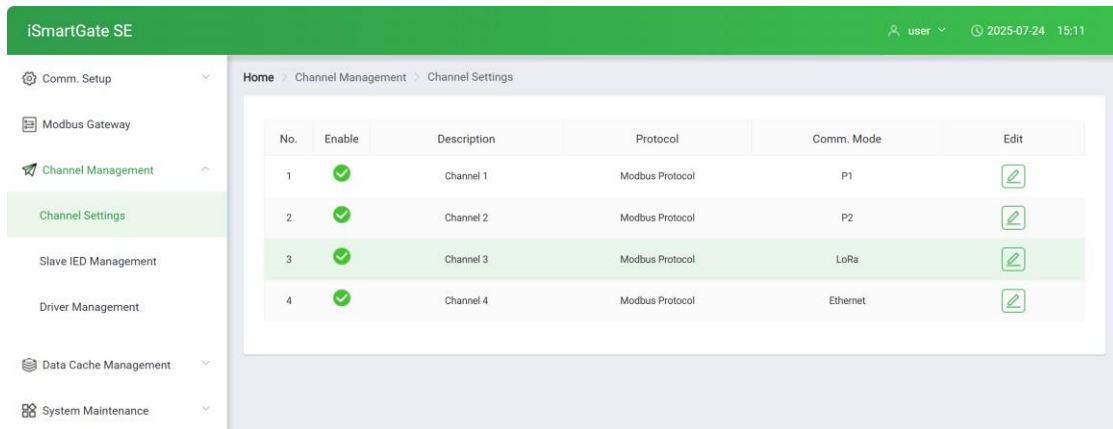

Figure 5-5 Channel Setting

2. Click **Channel Management > Slave IED Management** on the left-hand pane to manage connected IEDs. Please refer to **4.5 4.5.2** for details.

The screenshot displays the 'Slave IED Management' interface within the iSmartGate SE system. The interface includes a left-hand navigation menu with options like 'Comm. Setup', 'Modbus Gateway', 'Channel Management', 'Channel Settings', 'Slave IED Management', 'Driver Management', 'Data Cache Management', and 'System Maintenance'. The main content area shows a breadcrumb trail 'Home > Channel Management > Slave IED Management' and a dropdown menu for 'Channel 1'. There are 'Add IED' and 'Batch Delete' buttons at the top right. A table lists three IEDs with columns for No., Description, IED Model, Unit ID, Remark, Para. Map, Edit, and Delete. A 'Submit' button is located at the bottom center.

No.	Description	IED Model	Unit ID	Remark	Para. Map	Edit	Delete
1	dev_1	PMC-340-A6V10	1				
2	dev_2	PMC-220V103A	2				
3	dev_3	PMC-352-DVv09	3				

Figure 5-6 IED Management Setting

Chapter 6 Modbus Register Map

This chapter provides a complete description of the Modbus register map (**Protocol Version 1.0**) for the iSmartGate SE to facilitate the development of 3rd party communications driver for accessing information on the iSmartGate SE. For a complete Modbus Protocol Specification, please visit <http://www.modbus.org>. The iSmartGate SE supports the following Modbus functions:

- 1) Read Holding Registers (Function Code 0x03)
- 2) Force Single Coil (Function Code 0x05)
- 3) Preset Multiple Registers (Function Code 0x10)

The following table provides a description of the different data formats used for the Modbus registers. The iSmartGate SE uses the Big Endian byte ordering system.

Format	Description
UINT16/INT16	Unsigned/Signed 16-bit Integer
UINT32/INT32	Unsigned/Signed 32-bit Integer
Float	IEEE 754 32-bit Single Precision Floating Point Number

6.1 Analog Input Register

Register	Property	Description	Format
0000	RO	AI1	Float
0002	RO	AI2	Float
0004	RO	AI3	Float
...	RO	...	Float
1022	RO	AI512	Float

Table 6-1 AI Measurements

Notes:

- 1) The register value is invalid if the AIx's reading is 0x7FFFFFFF, which may indicate the AI's associated IDE is disconnected.

6.2 Digital Input Register

Register	Property	Description	Format
9000	RO	DI1~DI16	UINT16
9001	RO	DI17~DI32	UINT16
9002	RO	DI33~DI48	UINT16
...	RO	...	UINT16
9015	RO	DI241~DI256	UINT16

Table 6-2 DI Measurements

Notes:

- 1) Each of connected devices is defined as a virtual DI to show communication status, where 1 means **Connected**, while 0 means **Disconnected**.

6.3 Energy Register

Register	Property	Description	Format	Unit
10000	RO	PI1	INT64	0.01kWh
10004	RO	PI2	INT64	
10008	RO	PI3	INT64	
...	RO	...	INT64	
10508	RO	PI128	INT64	

Table 6-3 Energy Measurements

Notes:

- 1) The register value is invalid if the PIx's reading is 0x7FFFFFFF, which may indicate the PIx's associated IDE is disconnected.

6.4 Remote Control

Register	Property	Description	Format	Note
61000	WO	Arm Remote Control #1 Close/Open	UINT16	Writing "0xFF00" to the register execute the described action.
61001	WO	Execute Remote Control # 1 Close/Open	UINT16	
61002	WO	Arm Remote Control #2 Close/Open	UINT16	
61003	WO	Execute Remote Control #2 Close/Open	UINT16	
...	WO	...	UINT16	
61254	WO	Arm Remote Control #128 Close/Open	UINT16	

61255	WO	Execute Remote Control #128 Close/Open	UINT16	
-------	----	--	--------	--

Table 6-4 Remote Control

6.5 AO Register

Register	Property	Description	Format	Scale
63100~63101	WO	AO1	INT32	X100
63102~63103	WO	AO2	INT32	
63104~63105	WO	AO3	INT32	
...		...	INT32	
63354~63355	WO	AO128	INT32	

Table 6-5 AO Register

6.6 Time

Register	Property	Description	Format	Note
60000	WO	High-order Byte: Year-2000	UINT16	1-37
		Low-order Byte: Month		1 to 12
60001	WO	High-order Byte: Day	UINT16	1 to 31
		Low-order Byte: Hour		0 to 23
60002	WO	High-order Byte: Minute	UINT16	0 to 59
		Low-order Byte: Second		0 to 59
60003	WO	Millisecond	UINT16	0 to 999
60004	WO	UNIX Time	UINT132	

Table 6-6 Time Registers

6.7 Data Recorder Log

The real-time data, including AI and PI, is recorded as Data Recorder logs and stored in the iSmartGate SE storage. A DR log records all the AI and PI data in data cache at a certain moment.

Register	Property	Description	Format
30000	RO	DR Log Index	UINT32
30002	RW	Current DR Log Pointer	UINT32
30004	RO	DR Depth	UINT16
30005	RO	High-order Byte: Year	UINT16
		Low-order Byte: Month	
30006	RO	High-order Byte: Day	UINT16
		Low-order Byte: Hour	
30007	RO	High-order Byte: Minute	UINT16
		Low-order Byte: Second	

Table 6-7 Data Recorder Log

Notes:

- 1) **DR Log Index** indicates the latest DR Log index in data cache with a range of 0 and 0xFFFFFFFF. The register is incremented by 1 and will roll over to 1 when its current value is 0xFFFFFFFF.
- 2) The **Current DR Log Pointer** indicates its current reading position.

6.7.1 AI Log Buffer

Register	Property	Description	Format
30100	RO	AI1	Float
30102	RO	AI2	Float
30104	RO	AI3	Float
...		...	
38290	RO	AI4096	Float

Table 6-8 AI Log Buffer

6.7.2 PI Log Buffer

Register	Property	Description	Format	Unit
40000	RO	PI1	INT64	X0.01kWh
40004	RO	PI2	INT64	
40008	RO	PI3	INT64	
...		...		
48188	RO	PI2048	INT64	

Table 6-9 PI Log Buffer

6.8 Device Configuration

Register	Property	Description	Format	Note
60200	RO	CPU Load	Float	
60202	RO	RAM (MB)	Float	
60204	RO	Memory Usage	Float	
60206	RO	ROM (MB)	Float	
60208	RO	Available ROM	Float	
60210~60212	RO	Reserved	UINT16	
60213	RO	Alarm/DO Status	UINT16	

Table 6-10 Device Information

6.9 Device Information

Register	Property	Description	Format	Note
65000	RO	Device Model ¹	ASCII	
65020	RO	Firmware Version	UINT16	e.g. 10000 shows the version is V1.00.00
65021	RO	Modbus Version	UINT16	e.g. 10 shows the version is V1.0
65022	RO	Modbus Update Date: Year	UINT16	1-37 (Year-2000)
65023	RO	Modbus Update Date: Month	UINT16	1 to 12
65024	RO	Modbus Update Date: Day	UINT16	1 to 31
65025	RO	Energy Data Type	UINT16	0=INT32 1=INT64
65026	RO	Reserved	UINT16	

Table 6-11 Device Information

Note:

- 1) The Device Model appears in registers 65000 to 65019 and contains the ASCII encoding of the string "iSmartGate SE" as shown in the following table.

Register	Value(Hex)	ASCII
65000	0x69	i
65001	0x53	S
65002	0x6D	m
65003	0x61	a
65004	0x72	r
65006	0x74	t
65007	0x47	G
65008	0x61	a
65009	0x74	t
65010	0x65	e
65011	0x20	<Null>
65012	0x53	S
65013	0x45	E
65014~65019	0x20	<Null>

Table 6-12 ASCII Encoding of "iSmartGate SE"

6.10 Custom Data Registers

6.10.1 Analog Input Registers

Register	Property	Description	Format
0000	RW	AI1	Float
0002	RW	AI2	Float
0004	RW	AI3	Float
...	RW	...	Float
2046	RW	AI1024	Float

Table 6-13 Custom AI Registers

6.10.2 Digital Input Register

Register	Property	Description	Format
3000	RW	DI1	UINT16
3001	RW	DI2	UINT16
3002	RW	DI3	UINT16
...	RW	...	UINT16
4023	RW	DI1024	UINT16

Table 6-14 DI Measurements

6.10.3 Energy Register

Register	Property	Description	Format	Unit
5000	RW	PI1	INT64	0.01kWh
5004	RW	PI2	INT64	
5008	RW	PI3	INT64	
...	RW	...	INT64	
7044	RW	PI512	INT64	

Table 6-15 Energy Measurements

Appendix A - Technical Specifications

Communication	
Ethernet Port	
Speed	10/100 Mbps
Protocol	TCP, HTTP, MQTT, BACnet/IP, IEC 104
RS-485	
Baudrate	300/600/1200/2400/4800/9600/19200/38400 bps
Data Bits	5, 6, 7, 8
Stop Bits	1, 2
4G LTE CAT1 modem	
Type	4G LTE 2G GSM: 900/1800 MHz
Applicable to	
EU	Belgium, Britain, Cambodia, Denmark, Finland, France, Germany, Holland, Hong Kong (China), Indonesia, Italy, Japan, Korea, Lithuania, Macao (China), Malaysia, New Zealand, Norway, Pakistan, Philippines, Poland, Russia, Serbia, Singapore, South Africa, Spain, Sweden, Switzerland, Thailand, Tanzania, Vietnam, Zimbabwe, Nigeria, Algeria, etc.
SA	Argentina, Australia, Brazil, Chile, Saudi Arabia, Taiwan (China), Turkey, United Arab Emirates
NA	America, Canada, Mexico and Paraguay
LoRa (Optional)	
RF Range	860-930 MHz
ISM Bands	EU863-870, RU864-870, IN865-867, US902-928, AU915-928, AS920-923, AS923-925 and Custom
RF Output Power	18 dBm (Maximum)
Receiver Sensitivity	-136 dBm (Maximum)
Output Watts	0.03 (Typical)
FCC 47 CFR Part 15C	Certified
Power Supply (L/+, N/-)	
Standard	95-250VAC/DC ±10%, 47-440Hz
Optional	12-36VDC
Burden	≤3W
Protection	
ESD Protection	15kV (Air) & 8kV (Contact)
Isolation Protection	3kV for RS-485 1.5kV for Ethernet Port
Environmental Conditions	
Operating Temp.	-25°C to +70°C
Storage Temp.	-40°C to +85°C
Humidity	5% to 95% non-condensing
Atmospheric pressure	70kPa to 106kPa
Mechanical Characteristics	
Unit Dimensions	36x65x90mm
Mounting	DIN Rail
LoRa Antenna	
Frequency Range	860-935MHz
Band Width	75MHz
Impedance	50Ω
Power Capability	50W
Height	239.5±5mm
VSWR (Voltage Standing Wave Ratio)	≤2
Gain	2.0dBi
4G Antenna	
Frequency Range	699-960/1710-2690 MHz
Impedance	50Ω
Height	105±3mm
VSWR (Voltage Standing Wave Ratio)	≤2.5
Gain	>3.0dBi

Appendix B - Standards Compliance

Safety Requirements	
Audio/Video, Information and Communication Technology Equipment - Part 1: Safety Requirements	IEC 62368-1: 2014 + A1: 2017
Electromagnetic Compatibility CE EMC Directive 2014 / 30 / EU (EN 55035: 2017 + A11: 2020)	
Electrostatic Discharge	EN 61000-4-2: 2009
Radiated Fields	EN IEC 61000-4-3: 2020
Fast Transients	EN 61000-4-4: 2012
Surges	EN 61000-4-5: 2014 + A1: 2017
Conducted Disturbances	EN 61000-4-6: 2014
Magnetic Fields	EN 61000-4-8: 2010
Voltage Dips and Interruptions	EN IEC 61000-4-11: 2020
Emission Tests	
Electromagnetic Compatibility of Multimedia Equipment- Emission Requirements	EN 55032: 2015 + A11: 2020
Electromagnetic Compatibility of Multimedia Equipment- Immunity Requirements	EN 55035: 2017 + A11: 2020
Limits for Harmonic Current Emissions for Equipment with Rated Current ≤16 A	EN IEC 61000-3-2: 2019 + A1: 2021
Limitation of Voltage Fluctuations and Flicker in Low-Voltage Supply Systems For Equipment with Rated Current ≤16 A	EN 61000-3-3: 2013 + A1: 2019 + A2: 2021
Radiated Emission and Conducted Emission	ETSI EN 301 489-1 V2.2.3 ETSI EN 301 489-3 V2.3.2
Radio Equipment Directive (RED) 2014 / 53 /EU	
Assessment of Electronic and Electrical Equipment Related to Human Exposure Restrictions for Electromagnetic Fields (0 Hz - 300 GHz)	EN IEC 62311: 2020
Determination of RF Field Strength, Power Density and SAR in the Vicinity of Radio Communication Base Station for the Purpose of Evaluating Human Exposure	EN 62232: 2017
Short Range Devices (SDR) Operating in the Frequency Range 25 MHz to 1000 MHz	ETSI EN 300 220-1 V3.1.1: 2017 ETSI EN 300 220-2 V3.1.1: 2017
Mechanical Tests	
Freefall	IEC 60068-2-31: 2008
Vibration	IEC 60068-2-6: 2007
Shock	IEC 60068-2-27: 2008

Appendix C - Ordering Guide

Product Code		Description
iSmartGate SE Intelligent Gateway		
Basic Function		
R		<ul style="list-style-type: none"> • Modbus TCP/RTU Gateway and Transparent Gateway • Modbus Mastering with large 8GB On-Board memory and Max. number of data in Data Cache: 4096xAI, 4096xDI, 2024xEnergy, 1024xAO, 1024xDO, 2048xSOE Logs • Supports protocol conversion with, <ul style="list-style-type: none"> o Client protocols: Modbus RTU, Modbus TCP, IEC 104, Anypolling o Server protocols: IEC 104, Modbus TCP, MQTT+JSON, HTTP+JSON, AliCloud, Amazon AWS
B*		R option + BACnet/IP
Communication Ports		
T102		1x10Base-T/100Base-TX + 2xRS-485
LoRa		
N		None
7*		LoRa (860-930 MHz) configurable for EU863-870, RU864-870, IN865-867, US902-928, AU915-928, AS920-923, AS923-925
4G~¹		
NN		None
CN*		Applicable to India
EU*		Applicable to Europe and Southeast Asia Region
SA*		Applicable to South America
NA*		Applicable to North America
Power Supply		
2		95-250V AC/DC ± 10%
3*		12-36V DC
Language		
E		English
iSmartGate SE	- R - T102 - N - NN - 2 E	iSmartGate SE-R-T102-N-NN-2E (Standard Model)
* Additional charges apply.		
~ Applicable to 4G/3G/2G networks.		
1. The 4G options EU, SA and NA are applicable to the following countries and regions:		
EU	Belgium, Britain, Cambodia, Denmark, Finland, France, Germany, Holland, Hong Kong (China), Indonesia, Italy, Japan, Korea, Lithuania, Macao (China), Malaysia, New Zealand, Norway, Pakistan, Philippines, Poland, Russia, Serbia, Singapore, South Africa, Spain, Sweden, Switzerland, Thailand, Tanzania, Vietnam, Zimbabwe, Nigeria, Algeria, etc.	
SA	Argentina, Australia, Brazil, Chile, Saudi Arabia, Taiwan (China), Turkey, United Arab Emirates	
NA	America, Canada, Mexico and Paraguay	
2.SIM Card Requirement Micro-SIM.		